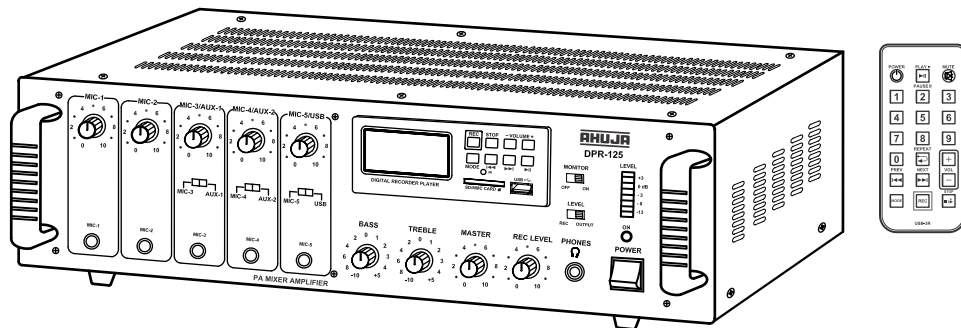

AHUJA[®]**PA Mixer Amplifier**

125W RMS/160W Max.

DPR-125

- ◆ Thank you for purchasing the AHUJA PA Mixer Amplifier.
- ◆ Please read this manual thoroughly before making connections and turning on the power. Following the instructions in this manual will enable you to obtain optimum performance from your new AHUJA PA Mixer Amplifier.
- ◆ Please retain this manual for future reference.

• Safety Instructions

Read the Instructions: Please read all the instructions in this section carefully before installation or use of the product. All the safety instructions must be followed.

Retain the Instructions: Please retain this Instruction Manual for future reference.



This symbol, wherever it appears, alerts you to the presence of uninsulated hazardous voltage that may be sufficient to constitute a risk of electric shock. External wiring to any terminal marked with this symbol must be done by a trained and instructed person only.



This symbol, wherever it appears adjacent to a component, alerts you that the concerned component can only be replaced by another of the exact same specifications.

WARNING

- To reduce the risk of electric shock, do not remove the top cover. No user serviceable parts inside. Refer all servicing to qualified personnel only.
- Before replacing any fuse, make sure the set is switched off and disconnected from the AC mains or any other power source. Replace a fuse only with another of exactly same specification.

CAUTIONS

Water & Moisture: To reduce the risk of fire or electrical shock, do not expose this set to rain or moisture. Do not use this set near water or in a wet location. Do not keep any object filled with liquid, such as a vase, on top of this set. Do not insert or remove the AC mains plug with wet hands.

Power Source: The voltage & frequency of the AC mains supply, and the voltage of the external battery, (if applicable) to which this set can be connected, is marked on the rear panel of the set. Do not connect this set to any power source other than those specified on the rear panel.

Power Cord Protection: Do not cut, kink, damage or modify the AC power cord supplied with this set. Keep the AC power cord away from heaters and harmful chemicals. Do not keep any heavy object on the power cord.

Operation on Generator: When operating this set on a generator, make sure the set is switched off till the generator voltage has stabilized.

Ventilation: This set should be situated so that its location or position does not interfere with its proper ventilation. Do not cover the ventilation holes / slots. Do not insert or drop anything into the ventilation holes / slots.

Stability: This set must be kept in a stable and flat horizontal position, and never in a tilted position. Do not place this set on an unstable stand, tripod, bracket or mount. Do not use attachments which are not supplied or explicitly recommended by the manufacturer.

Cover Strip: The cover strip of the 100V / 70V audio output terminal strip, and of any other high voltage output terminal strip, must be replaced after making connections. Failure to do so may result in exposure to hazardous voltages.

Earthing: This set must be earthed properly before use. A wire from the Earth terminal on the rear panel must be connected to electrical earth.

Cleaning: Disconnect this equipment from the AC mains and external battery before cleaning. Clean with a damp cloth, but do not allow any liquid to enter the set. Do not clean with liquids or aerosols.

Exposure to Heat: Do not touch the heatsinks while the set is working.

• Table of Contents

Contents	Page No.
● Features / General Description of Product	4
● Front Panel Controls & Features	5
● Rear Panel Controls & Features	6
● MP3 Playback Facility: Controls & Features	7
● Operating Procedure	8
● Interconnections	9
● Speaker Connection Guidelines	10
● Specifications	12

• Features/General Description of Product

- Designed for use in a wide variety of PA applications.
- DPR-125 is a 125 Watts Mixer Amplifier with two unbalanced independent Mic inputs and further three unbalanced Mic inputs alternate to AUX-1, AUX-2 and USB.
- Built-in MP3 recorder player with large display LCD supplied with separate remote.
- DPR-125 has a Preamp output for connecting to AUX input of another amplifier and a Line output for connecting to a line input of another amplifier.
- Active Bass and Treble Controls have been provided which help to shape the tonal quality of music and speech to the desired requirement.
- LED array has been provided for visual monitoring of output level as well as for adjustment of recording signal level.
- Provision for automatic changeover from AC to Battery Operation ensures continuity of program (if 12V battery is connected).
- Protection provided against the reverse polarity of battery connections.
- Ease of operation, combined with service accessibility has been optimized in the design.
- Headphone socket provided for listening or monitoring the program.
- 2.5" Monitor speaker built-in for monitoring the program played.

• Front Panel Controls & Features

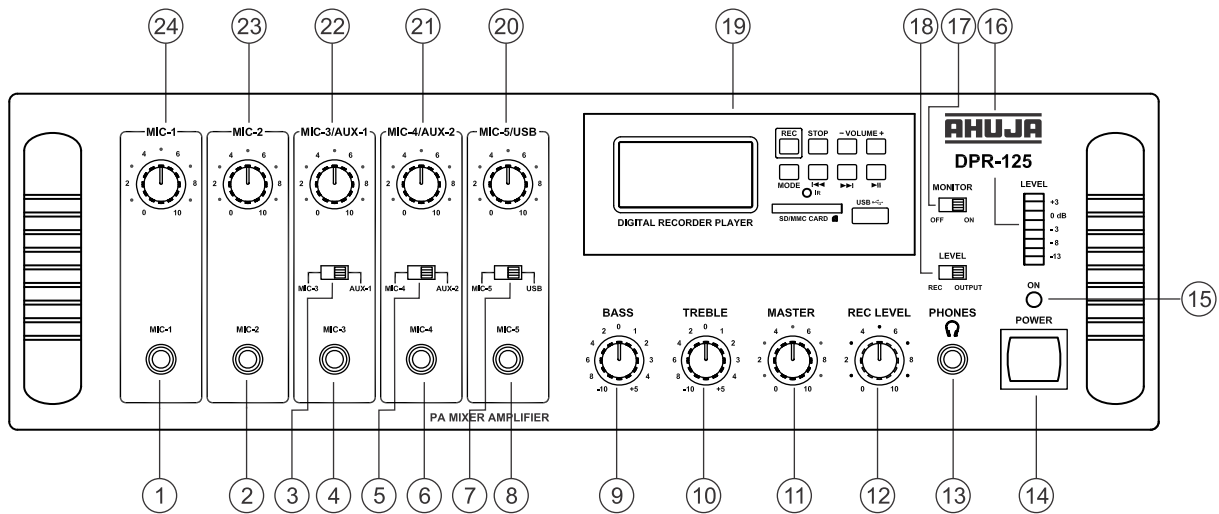

1. **MIC-1 Input Jack Socket** : For accepting unbalanced signal from a low impedance microphone.
2. **MIC-2 Input Jack Socket**
3. **MIC-3 / AUX-1 Selector Switch**
4. **MIC-3 Input Jack Socket**
5. **MIC-4 / AUX-2 Selector Switch**
6. **MIC-4 Input Jack Socket**
7. **MIC-5 / USB Selector Switch**
8. **MIC-5 Input Jack Socket**
9. **BASS Control**: To attenuate or boost the signal level of low frequencies.
10. **TREBLE Control**: To attenuate or boost the signal level of high frequencies.
11. **MASTER Volume Control**: To adjust the overall volume level of the amplifier.
12. **Rec Level Control**: To adjust the level of program to be recorded.
13. **Headphone**: To connect the headphone for monitoring or listening to the program.
14. **POWER Switch**: Push the top part of the knob to switch the amplifier ON. Push the bottom part of the knob to switch the amplifier OFF.
15. **POWER LED**: This LED glows when the amplifier power is ON.
16. **LED Array**: This indicates the output level of the amplifier as well as level of recorded signal.
17. To switch ON or OFF the monitor speaker output fitted on rear panel.
18. To switch the LED array (16) between RECORDING LEVEL DISPLAY and OUTPUT LEVEL DISPLAY
19. **MP3 Playback Facility** (see description page 7)
20. **MIC-5 / USB Volume Control**
21. **MIC-4 / AUX-2 Volume Control**
22. **MIC-3 / AUX-1 Volume Control**
23. **MIC-2 Volume Control**
24. **MIC-1 Volume Control**

NOTE: USB playback level is also controlled by the volume “+” / volume “-” controls on the USB panel and remote control. If USB playback level appears to be insufficient even after turning rotary control (20) fully clockwise, check USB volume setting from the “+” / “-” controls on the remote or the USB panel.

• Rear Panel Controls & Features

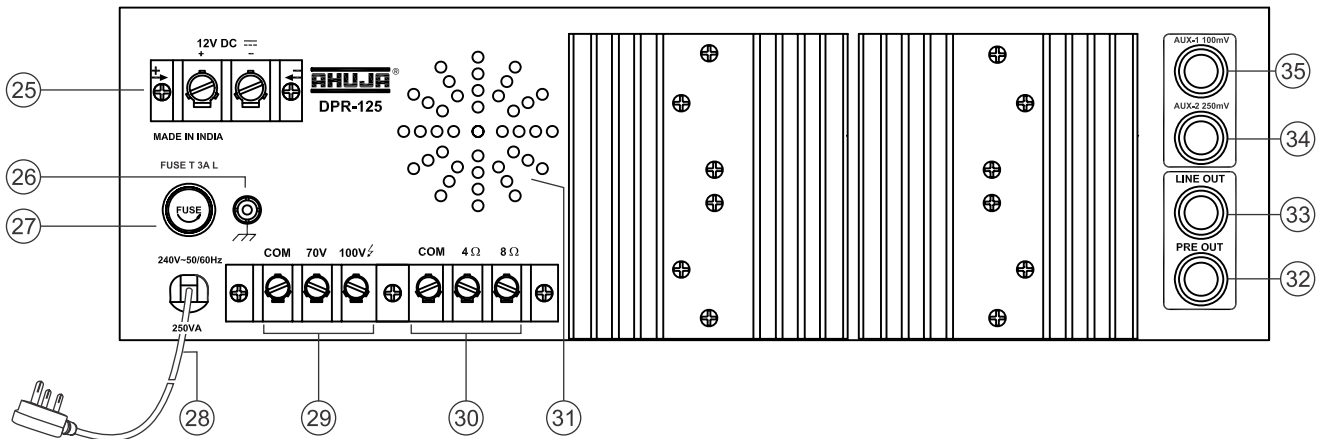

25. BATTERY Terminal Block

For connecting a 12V Car Battery as standby power source.

26. EARTH Terminal

27. AC MAINS FUSE Rating 3 Amp. (T 3A L)

This protects the amplifier from any excessive current flow.

28. 3 Core AC Mains Cable With Plug

29. SPEAKER Terminal Block (COM, 70V, 100V)

For connecting speakers with 100V line matching transformers.

30. SPEAKER Terminal Block (COM, 4 Ohm, 8 Ohm)

For connecting low impedance speakers.

31. Monitor Speaker: To listen and monitor the quality of program played through DPR-125.

32. PREAMPLIFIER Output Jack Socket

For connecting to the AUX input of another amplifier.

33. LINE Output Jack Socket

For connecting to a booster amplifier to obtain combined higher power output.

34. AUX-2 Input (250mV) Jack Socket

For accepting an unbalanced signal from an auxiliary source like a Tuner, MP3 Player, Echo unit or CD Player etc.

35. AUX-1 Input (100mV) Jack Socket

For accepting an unbalanced signal from an auxiliary source like a Tuner, MP3 Player, Echo unit or CD Player etc.

Caution

- The equipment must be earthed properly before operating it to avoid electric shock. A wire from the Earth Terminal must be connected to electrical earth for safe operation.

• MP3 Playback Facility: Controls & Features

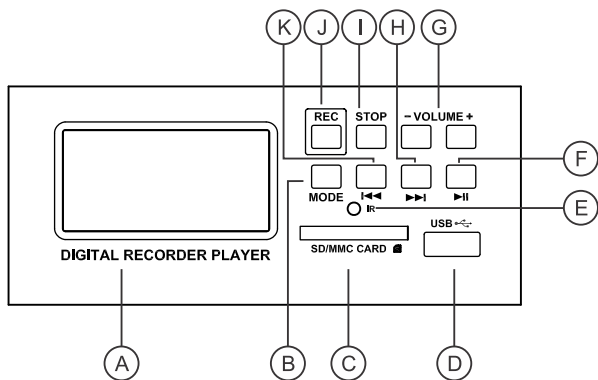

- A. LED Display:** Momentarily displays 3 digits of the track selected to play i.e 001 to 999. During play, displays the time duration of the track played.
- B. Mode:** To select USB or SD card when both are inserted.
- C. SD/MMC Card Connector:** Insert the SD/MMC Card into its appropriate slot to play. When taking out the card, pull the card to take out.

While inserting SD/MMC card into the slot, ensure that the card is inserted in such a way that all pins are facing upward and cut is towards left as shown in figure.

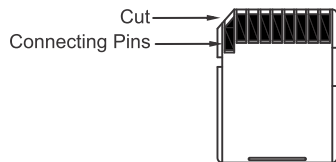

- D. USB Connector:** Insert the USB drive here. While inserting USB drive into the USB connector, hold the USB drive in such a way that hollow part of the USB drive is downwards as shown in Figure.

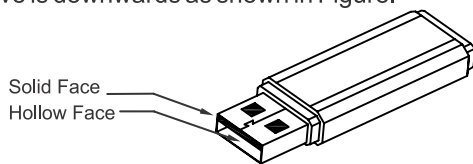

Any forceful insertion in wrong direction will damage the connector.

- E. IR Sensor:** Picks up signal from the Remote control. Point the Remote control toward this sensor for best results.
- F. PLAY/PAUSE:** Press PLAY/PAUSE once to Pause if music is already playing. Press PLAY/PAUSE again to resume playing.
- G. VOL+ :** To increase volume level of MP3 player.
VOL- : To decrease volume level of MP3 player.
- H. NEXT:** Press NEXT to select next forward music track. Pressing NEXT repeatedly will move the system to successively next forward tracks. Press for longer duration to access the next folder.
- I. STOP:** Press this key to stop PLAY or REC function.
- J. REC:** Press this switch once and, the system will be ready to record. Press REC again and, the system will

Remote Control

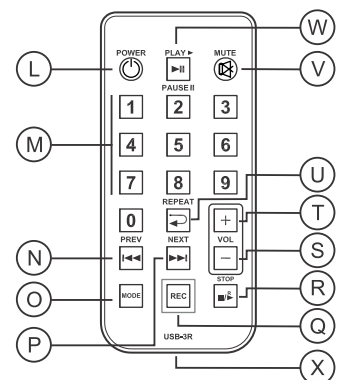

start recording. Press again to PAUSE the recording and press once again to resume the recording from same point on the same track.

- K. PREV:** Press PREV to Select the previous track. Pressing PREV repeatedly will move the system to successively previous tracks. Press for longer duration to access previous folder.

Remote Control

- L. Power:** Press once to switch off MP3 player, press again to switch ON.
- M. Number key 0 to 9.** To choose the track number to be played.
- N. PREV:** To select the previous track. Press for longer duration to access previous folder.
- O. MODE:** To select SD or USB if both are inserted.
- P. NEXT:** Press to select the next track. Press for longer duration to access next folder.
- Q. REC:** Press this switch once and, the system will be ready to record. Press REC again and, the system will start recording. Press again to PAUSE the recording and press once again to resume the recording from same point on the same track.
- R. STOP:** Press to stop the track being played.
- S. -Vol:** Press to decrease the volume of MP3 Player.
- T. +Vol:** Press to increase the volume of MP3 Player.
- U. REPEAT:** Press once to repeat the song being played. Press again to repeat all the songs.
- V. MUTE:** Press once to mute the sound, press again the resume the sound.
- W. PLAY/PAUSE:** Press Play/Pause once to Pause when music is already playing. Press Play/Pause again to resume playing.
- X. Battery Replacement:** Pull out the battery tray and replace the battery with positive electrode facing upwards as shown in fig. below. Push the battery compartment back to the close position. Use CR2025 or equivalent lithium coin cell.

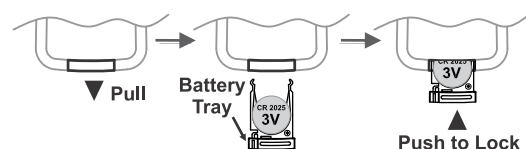

• Operating Procedure

- (1) Set all volume controls to '0' position and keep the power switch at OFF position. Connect the speakers and required inputs.

Plug in the AC power cord to the nearest AC mains socket and put the power switch to ON position. The power ON LED should glow.

- (2) Select the Mic or Aux input to use and increase the respective control to desired level.

System as a Player:-

- a) Select the switch MIC 5/USB to USB position. The display will blink "ON" three times and then show "---".
- b) Insert the pen drive or SD card into the respective port. For a moment display will show the folder and the track no. being played.

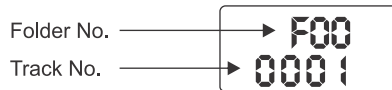

- c) When the MP3 player starts playing, the display shows in first line the track no. being played, in the second line the time elapsed.



- d) Use the volume button on the remote control or on the module to adjust the desired USB playback level. Use remote control to select the desired track to be played.

- e) Press STOP to stop the track being played. The second line of the display shows STOP.



- f) Setting of volume level remains in memory as long as no power failure occurs. If power is switched OFF and then ON again, volume level goes to the default level.
- g) Bass and Treble setting can be done for desired tonal quality.
- h) Use remote control to switch OFF the USB MP3 recorder player while not in use.

System as Recorder:-

- a) Insert the pen drive or SD card into the respective port.
- b) Press REC button once. The module will become ready to record. Display will show rEC (blinking) and track no. of recording.

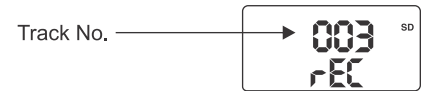

- c) Select Mic or Aux input signals to record. Press REC button second time, the system will start recording and display will show the track no., time elapsed, & REC status.



- d) Switch the level switch REC/OUTPUT to 'REC' position and increase the recording level control such that 0dB LED on the LED array just glows occasionally.

- e) If need arises to PAUSE the recording press REC button third time, it will PAUSE the recording. Press REC again to resume the recording. It will start recording in the same file and from the same point where it paused earlier.

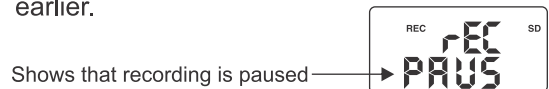

- f) Press STOP to stop recording. If you want to record again then proceed same as above. The module will generate next file for recording.

- g) To play the recorded program, press PLAY. The module will start playing the last file recorded.

- (6) To search for folder, press NEXT or PREV for longer period, it will display the folder. Select the desired folder and press PLAY, the module start playing from the track one of that folder.

• Interconnections

- The amplifier should be placed as a tabletop unit. The amplifier should be situated so that its location or position does not interfere with its proper ventilation.
- The amplifier must be powered through an AC earthed mains outlet.
- The amplifier may also be operated from a DC supply of 12 Volts (one car battery).
- All connections must only be carried out or changed with the amplifier switched OFF and the power cord disconnected from the AC mains.
- To avoid loud switching noise, always switch ON the amplifier after all other units of the audio system (like mixer) have been switched ON. After operation, switch the amplifier OFF first, then the other units.
- Always use sufficiently thick cables for speaker connection in order to avoid power losses in the cables. Use of 40/36 or thicker cable is recommended when low impedance speakers are being used.
- The connection diagrams that follow display typical types of input sources and speakers which can be connected to the amplifier. For correct connections and operation check, the specifications of the connected equipment.

REAR PANEL - DPR-125

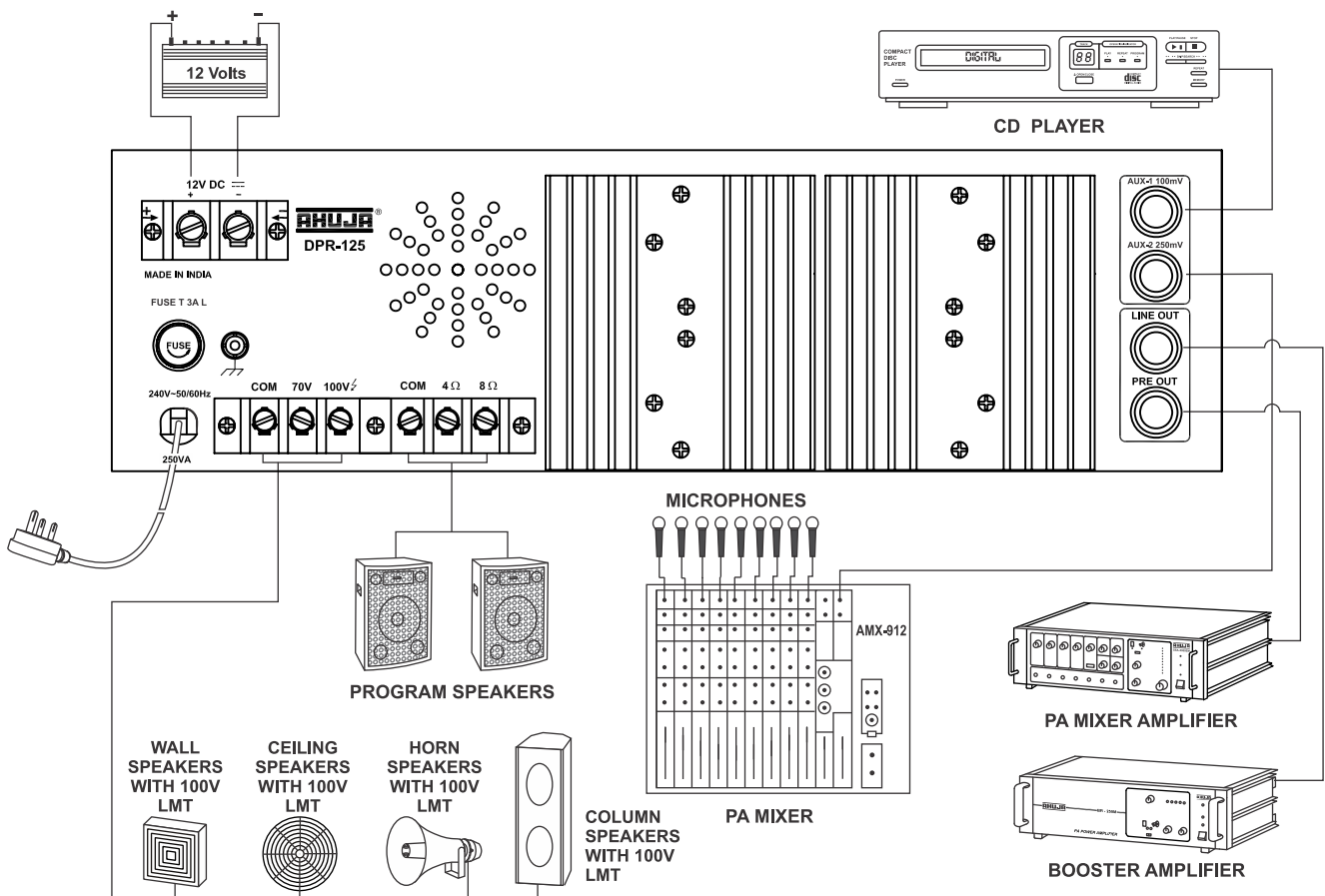

• Speaker Connection Guidelines

It is important that correct loudspeaker connections are made to avoid damage to the amplifiers or speakers.

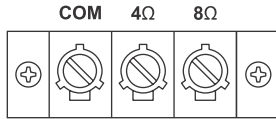

Low Impedance Speaker Connections

- Box type speakers like SAX-150DX / SRX-120DX can be directly connected to COM-4Ω / 8Ω terminal strip.
- Driver units without LMT like AU-40 / AU-60 can be directly connected to COM-4Ω / 8Ω terminal strip.
- PA Wall Speakers like SMX-602 (8Ω tap) can be directly connected to COM-4Ω / 8Ω terminal strip.

Connecting one SAX-200DX Speaker

SAX-200DX speaker (200W) should be connected to COM & 8Ω tap as shown in the figure.

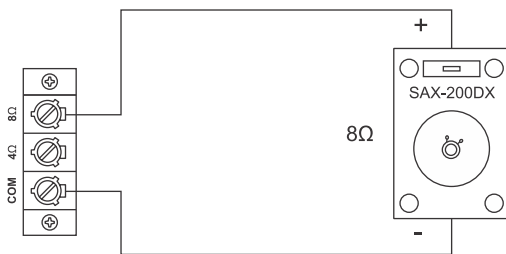

Connecting two SRX-120DX Speakers

The loudspeakers like SRX-120DX should be wired in parallel as shown in the figure. As the resulting impedance of the speaker system is 4Ω, they should be connected to the 4Ω tap of the amplifier.

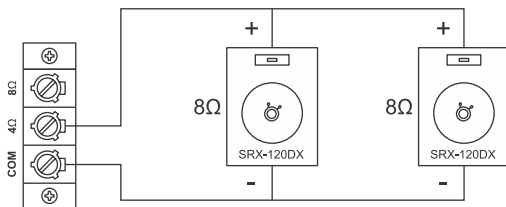

Resultant Impedance = $8/2 = 4\Omega$

Connecting four Wall Speakers like SMX-602

If it is required to use wall speaker on low impedance tap, then four PA Wall Speakers like SMX-602 (8Ω tap) can be wired in two groups of two wall speakers each (in parallel) and then connecting the two groups in series as shown in figure. As the resulting impedance of the speaker system is 8Ω, they should be connected to the 8Ω tap of the amplifier.

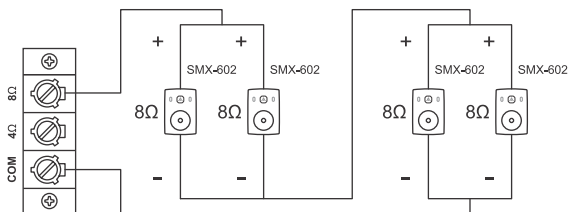

Resultant Impedance = $(8/2) + (8/2) = 8\Omega$

Speaker Connection Guidelines....

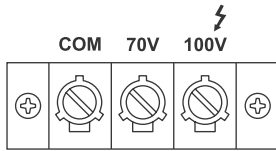

High Impedance Speakers or Speakers Using A 100V Line Matching Transformer

- Only Driver Units / Horn Speakers / Column Speakers / Wall Speakers with 100V Line Matching Transformers are to be connected to Com-70V / 100V Terminal Strip.
- The power drawn from the amplifier should not exceed 125 Watts.

Connecting Four Driver Units with 100V LMT

- 4 Driver Units with 100V Line Matching Transformer each connected at 30 Watts tap can be operated as shown.

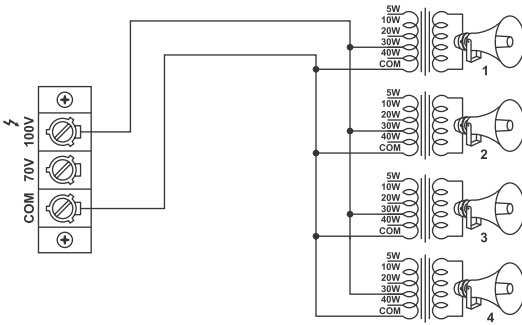

Connecting a Combination of Driver Units and Column Speakers with 100V LMT

- 7 Column Speakers with 100V LMT at 10 Watts and 11 Driver Units with 100V LMT at 5 Watts can be connected together. The power drawn from the amplifier should not exceed 125 Watts.

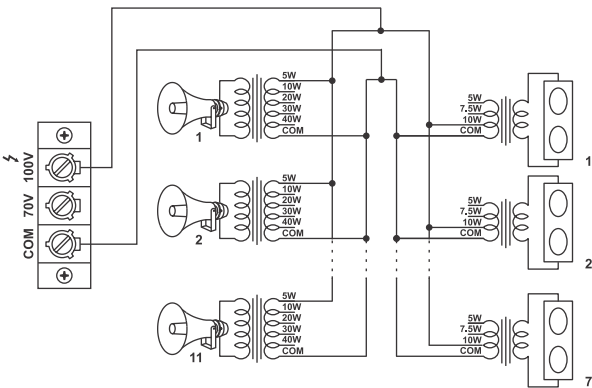

Use of 70 Volt Line

A loudspeaker / Driver Unit with its LMT adjusted to the 10W tap, when connected to COM and 100V terminals on the amplifier's Terminal Strip will draw 10W from the amplifier but when the same is connected to COM and 70V it will only draw half power i.e. 5W. A good use of 70V line tap can be made in installations where large number of speakers / driver units are to be installed for more even distribution of sound.

Correct Phasing of Loudspeakers

- When two or more Speakers / Units installed in the same area and are facing the same direction, it is essential that their cones / diaphragms act in unison. Otherwise the sound level of one speaker will cancel the sound level of the other. To avoid any mistake, the terminals of Box speakers and the Driver Units are marked '+' & '-'. Always connect the COM of the Amplifier to '-' of speaker & 4 / 8Ω of the amplifier to the '+' of the speakers.
- In case of LMTs the COM of all the LMTs should be connected to the COM of the red strip terminal of the amplifier and the power tap to 100V line as shown above.

IMPORTANT

- When speakers are connected to COM-4Ω / 8Ω Terminal Strip, no speaker should be connected to the Terminal Strip marked COM-70V / 100V. Speaker should be connected to COM and only one of the taps 4Ω, 8Ω.
- When 70 / 100 Volt line is being used, no speaker / driver unit should be connected to 4Ω / 8Ω (Low Impedance) Tap. Speakers should be connected to COM and only one of the taps 700V or 100V.

• Specifications

Model	DPR-125
Power Output	160 Watts RMS Max. 125 Watts RMS at 10% THD 105 Watts RMS at 5% THD
Output Regulation	≤2db (no load to full load at 1kHz)
Inputs Channels	5 × Mic 0.65mV / 4.7kΩ Aux-1 : 100mV / 470kΩ Aux-2 : 250mV / 470kΩ
Digital Recorder Player	MP3 Recorder Player with Remote Control (USB, SD and MMC card reader)
Frequency Response	50Hz - 15,000Hz ± 3dB
Tone Controls	Bass: +5dB, -10dB at 100Hz Treble: +5dB, -10dB at 10kHz
Signal to Noise Ratio	60dB
Pre-amp Output	200mV / 600Ω
Line Output	1V / 1kΩ
Output Taps for Speaker Matching	4Ω, 8Ω (for direct connections) 70V & 100V Line (for use with LMT)
Power Source	AC: 220-240V 50 / 60Hz; DC:12V (Car Battery)
Protection	AC: Fuse 3Amp. (T 3A L); DC: Fuse 14Amp. (T 14A L)
Power Consumption	AC: 250VA; DC: 5.5 Amps (average)
Dimensions	W425 × H135 × D290 mm
Weight	11.50 kg approx.

- Design and Specifications are subject to change without notice owing to continuous product upgradation.
- Technical specifications are subject to production tolerances.

Design and Specifications are subject to change without notice owing to continuous product up-gradation. Technical specifications are subject to production tolerances.

We cannot be held responsible for printing errors, should they occur. **airtel** is a registered trademark of Ahuja Radios in India and other countries.

© Copyright Ahuja Radios, 2013. All rights reserved. Any unauthorized reproduction or use of logos, images or design elements is strictly prohibited by law.

No part of this compilation may be reproduced in any manner or translated without written permission.

TRUSOUND PVT. LTD. • C-89, Sector IV, Noida, Gautam Budh Nagar-201 301 (UP)

Regd. Office : 125E, Okhla Industrial Estate, New Delhi-110 020

Tel.: +91-120-4665665 Fax : +91-120-4665621

E-mail: trusoundsupport@airtelmail.in

E. & O. E. 0K/09/13