

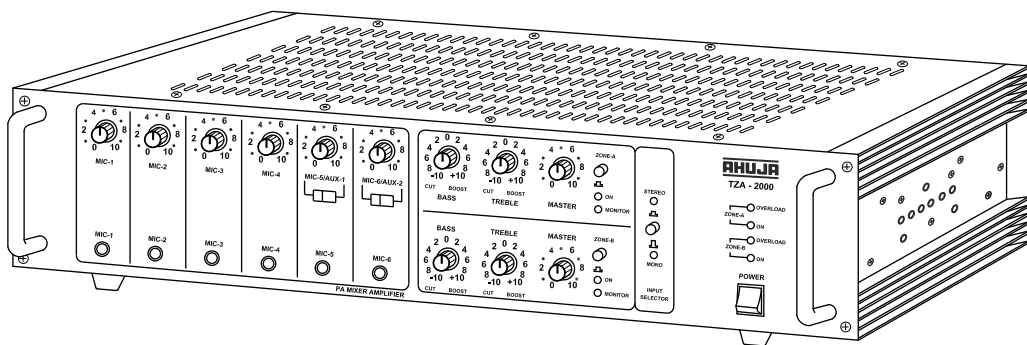

PA Mixer Amplifier

200W RMS/260W Max.

TZA-2000[®]



- ◆ Thank you for purchasing the AHUJA PA Mixer Amplifier.
- ◆ Please read this manual thoroughly before making connections and turning on the power. Following the instructions in this manual will enable you to obtain optimum performance from your new AHUJA PA Mixer Amplifier.
- ◆ Please retain this manual for future reference.

• Safety Instructions

Read the Instructions: Please read all the instructions in this section carefully before installation or use of the product. All the safety instructions must be followed.

Retain the Instructions: Please retain this Instruction Manual for future reference.



This symbol, wherever it appears, alerts you to the presence of uninsulated hazardous voltage that may be sufficient to constitute a risk of electric shock. External wiring to any terminal marked with this symbol must be done by a trained and instructed person only.



This symbol, wherever it appears adjacent to a component, alerts you that the concerned component can only be replaced by another of the exact same specifications.

WARNING

- To reduce the risk of electric shock, do not remove the top cover. No user serviceable parts inside. Refer all servicing to qualified personnel only.
- Before replacing any fuse, make sure the set is switched off and disconnected from the AC mains or any other power source. Replace a fuse only with another of exactly same specification.

CAUTIONS

Water & Moisture: To reduce the risk of fire or electrical shock, do not expose this set to rain or moisture. Do not use this set near water or in a wet location. Do not keep any object filled with liquid, such as a vase, on top of this set. Do not insert or remove the AC mains plug with wet hands.

Power Source: The voltage & frequency of the AC mains supply, and the voltage of the external battery, (if applicable) to which this set can be connected, is marked on the rear panel of the set. Do not connect this set to any power source other than those specified on the rear panel.

Power Cord Protection: Do not cut, kink, damage or modify the AC power cord supplied with this set. Keep the AC power cord away from heaters and harmful chemicals. Do not keep any heavy object on the power cord.

Operation on Generator: When operating this set on a generator, make sure the set is switched off till the generator voltage has stabilized.

Ventilation: This set should be situated so that its location or position does not interfere with its proper ventilation. Do not cover the ventilation holes / slots. Do not insert or drop anything into the ventilation holes / slots.

Stability: This set must be kept in a stable and flat horizontal position, and never in a tilted position. Do not place this set on an unstable stand, tripod, bracket or mount. Do not use attachments which are not supplied or explicitly recommended by the manufacturer.

Cover Strip: The cover strip of the 100V / 70V audio output terminal strip, and of any other high voltage output terminal strip, must be replaced after making connections. Failure to do so may result in exposure to hazardous voltages.

Earthing: This set must be earthed properly before use. A wire from the Earth terminal on the rear panel must be connected to electrical earth.

Cleaning: Disconnect this equipment from the AC mains and external battery before cleaning. Clean with a damp cloth, but do not allow any liquid to enter the set. Do not clean with liquids or aerosols.

Exposure to Heat: Do not touch the heatsinks while the set is working.

• Table of Contents

Contents	Page No.
• Features/General Description of Product	4
• Front Panel Controls & Features	5
• Rear Panel Controls & Features	6
• Interconnections	7
• Speaker Connection Guidelines	9
• Typical Applications	12
• Specifications	14

• Features/General Description of Product

- Ideal for use in a wide variety of 2- Zone PA applications where high power is required.
- TZA-2000® is a 200 Watts 2-Zone mixer amplifier with each zone having its independent tone and master controls for separate and combined operation.
- Line Outputs have been provided for each zone separately to enable interconnections with other power amplifiers for more power if the need arises.
- The amplifier has Mono and Stereo input jacks. Thus it can be used for Stereo music reproduction as well as mono. Switching of Stereo/Mono can be done using 'STEREO/MONO' switch provided in the front panel.
- TZA-2000® has individual Zone ON/OFF facility. Sound from each zone can be switched ON and OFF without disturbing the settings of tone and volume controls. LEDs are provided for individual zone ON/OFF.
- 10 Amp DC Fuse has been provided for each zone. It safeguards the amplifier against overload and short circuit.
- Power losses in speaker wirings are reduced as the Two zones share the delivering of 200W of power.
- Provision for automatic changeover from AC to battery operation ensuring continuity of program.
- Protection provided against the reverse polarity of battery connections.
- Ease of operation, combined with service accessibility has been optimized in the design.

• Front Panel Controls & Features

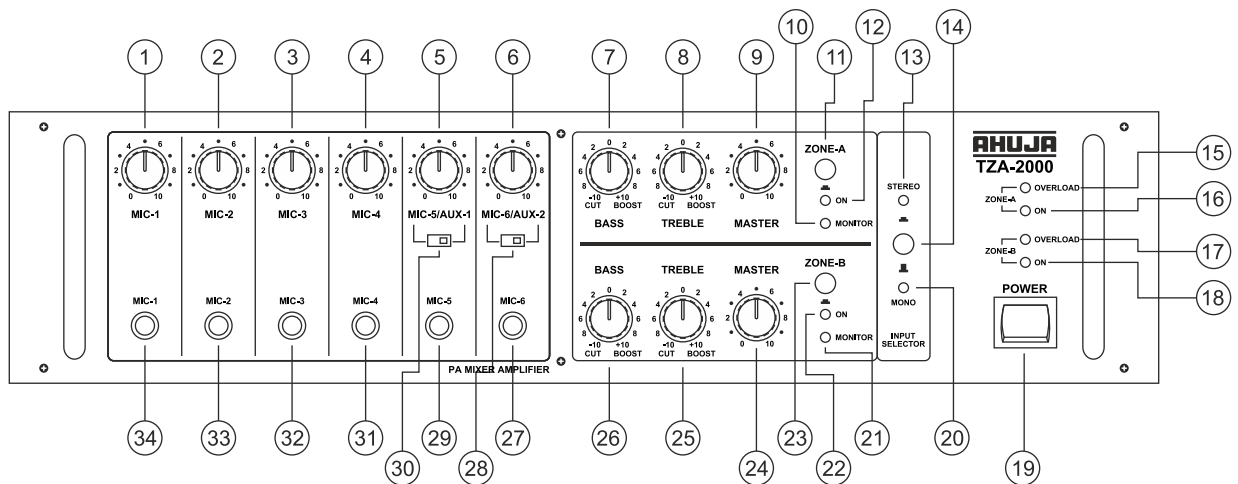

1. **MIC-1 Volume Control**
2. **MIC-2 Volume Control**
3. **MIC-3 Volume Control**
4. **MIC-4 Volume Control**
5. **MIC-5 / AUX-1 Volume Control**
6. **MIC-6 / AUX-2 Volume Control**
7. **BASS Control (Zone A)**
For cutting or boosting the signal level of low frequencies.
8. **TREBLE Control (Zone A)**
For cutting or boosting the signal level of high frequencies.
9. **MASTER Volume Control (Zone A)**
For adjustment of the volume level.
10. **MONITOR (Zone A)**
For monitoring the output level of Zone A.
11. **ON/OFF Switch (Zone A)**
12. **LED for Zone A on/off indication**
13. **LED for Stereo input**
This LED grows up when 'MONO / STEREO' input selector switch is set to 'STEREO' position.
14. **MONO / STEREO input Selector Switch**
For STEREO playback from Cassettes and CDs this switch must be pressed. The Master and Tone Controls of Zone-A and Zone-B will control the volume of Left and Right channels. For MONO operation the switch must be released.
15. **OVERLOAD LED (Zone A)**
This LED glows when the DC fuse blows.
16. **Power LED (Zone A)**
This LED glows when the amplifier is switched ON.
17. **OVERLOAD LED (Zone B)**
18. **Power LED (Zone B)**
19. **POWER Switch**
Push the top part of the knob to switch the amplifier ON. Push the bottom part of the knob to switch the amplifier OFF.
20. **LED for Mono input**
This LED grows up when 'MONO / STEREO' input selector switch is set to 'MONO' position.
21. **MONITOR (Zone B)**
22. **LED for Zone B ON/OFF indication**
23. **ON/OFF Switch (Zone B)**
24. **MASTER Volume Control (Zone B)**
25. **TREBLE Control (Zone B)**
26. **BASS Control (Zone B)**
27. **MIC-6 Input Jack Socket**
28. **MIC-6 / AUX-2 Selector Switch**
29. **MIC-5 Input Jack Socket**
30. **MIC-5 / AUX-1 Selector Switch**
31. **MIC-4 Input Jack Socket**
32. **MIC-3 Input Jack Socket**
33. **MIC-2 Input Jack Socket**
34. **MIC-1 Input Jack Socket**

• Rear Panel Controls & Features

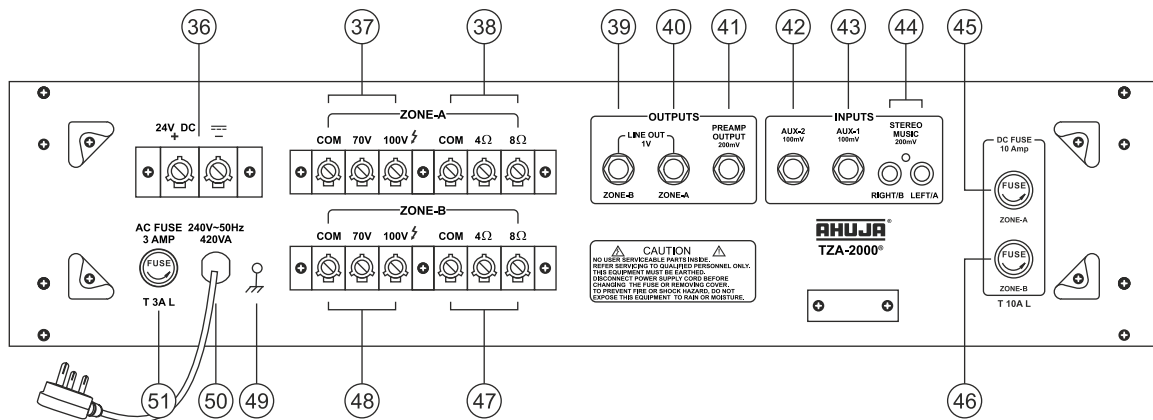

36. BATTERY Terminal Block

For connecting two 12V Car Batteries in series (which becomes 24V) as standby power source.

37. SPEAKER Terminal Block for Zone A (70 and 100V)

For connecting speakers with 100V line matching transformers.

38. SPEAKER Terminal Block for Zone A (4Ω and 8Ω)

For connecting low impedance speakers.

39. LINE Output Jack Socket for Zone A

For connecting to the LINE Input of a booster amplifier to obtain combined higher power output.

40. LINE Output Jack Socket for Zone B

41. PREAMPLIFIER Output Jack Socket

For connecting to the AUX input of another amplifier or a recorder for recording purpose.

42. AUX-2 Input Jack Socket

For accepting an unbalanced signal from an auxiliary source like a Tuner, MP3 Player, Echo or Audio Mixer etc.

43. AUX-1 Input Jack Socket

44. STEREO RCA Jack

These two RCA Jacks for connecting STEREO Input from a MP3 Player or CD Player.

45. Zone A 10 Amp DC Fuse (T 10A L)

46. Zone B 10 Amp DC Fuse (T 10A L)

47. SPEAKER Terminal Block for Zone B (4Ω and 8Ω)

48. SPEAKER Terminal Block for Zone B (70 and 100V)

49. EARTH Terminal

50. 3 CORE AC MAINS CABLE WITH PLUG

51. AC MAINS FUSE Rating 3 AMP 250V (T 3A L)

CAUTION

- The equipment must be earthed properly before operating it to avoid electric shock. A wire from the Earth Terminal must be connected to electrical earth for safe operation.

• Interconnections

- The amplifier can be placed as a tabletop unit. Considerable heat is generated inside the amplifier during continuous use, therefore, the amplifier should be situated so that its location or position does not interfere with its proper ventilation.
- The amplifier must be powered through an AC earthed mains outlet.
- All connections must be carried out or changed only when the amplifier is switched OFF.
- The amplifier may be operated from a DC supply of 24 Volts (two car batteries connected in series).
- To avoid loud switching noise, always switch ON the amplifier after all other units of the audio system have been switched ON. After operation switch it OFF first and then the other units.
- The connection diagram below, displays the typical types of input sources (Mics, Keyboard, MP3 Player, Mixer, CD Player etc.) and speakers (Wall, Ceiling, Box, Horn, Column) which can be connected to the amplifier. For correct connections and operation check the specifications of the connected equipment.

FRONT PANEL - TZA-2000®

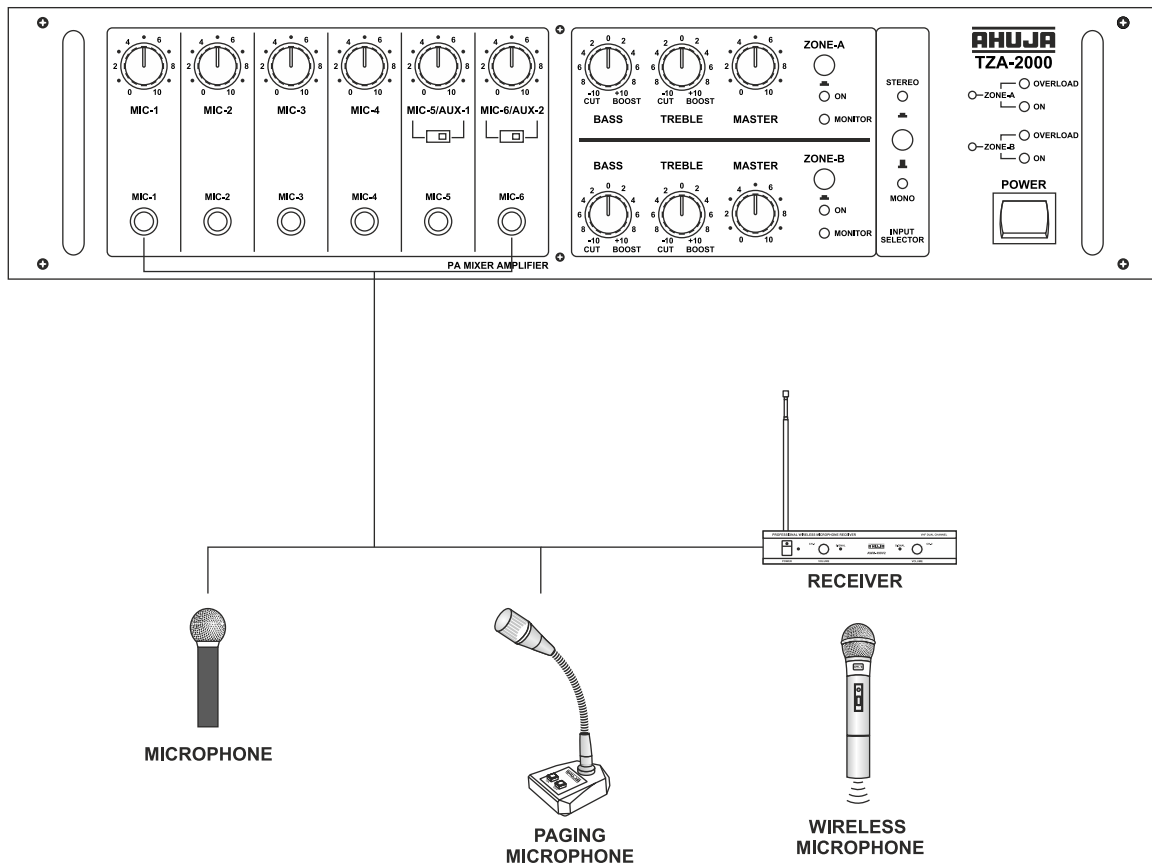

• Interconnections....

REAR PANEL - TZA-2000®

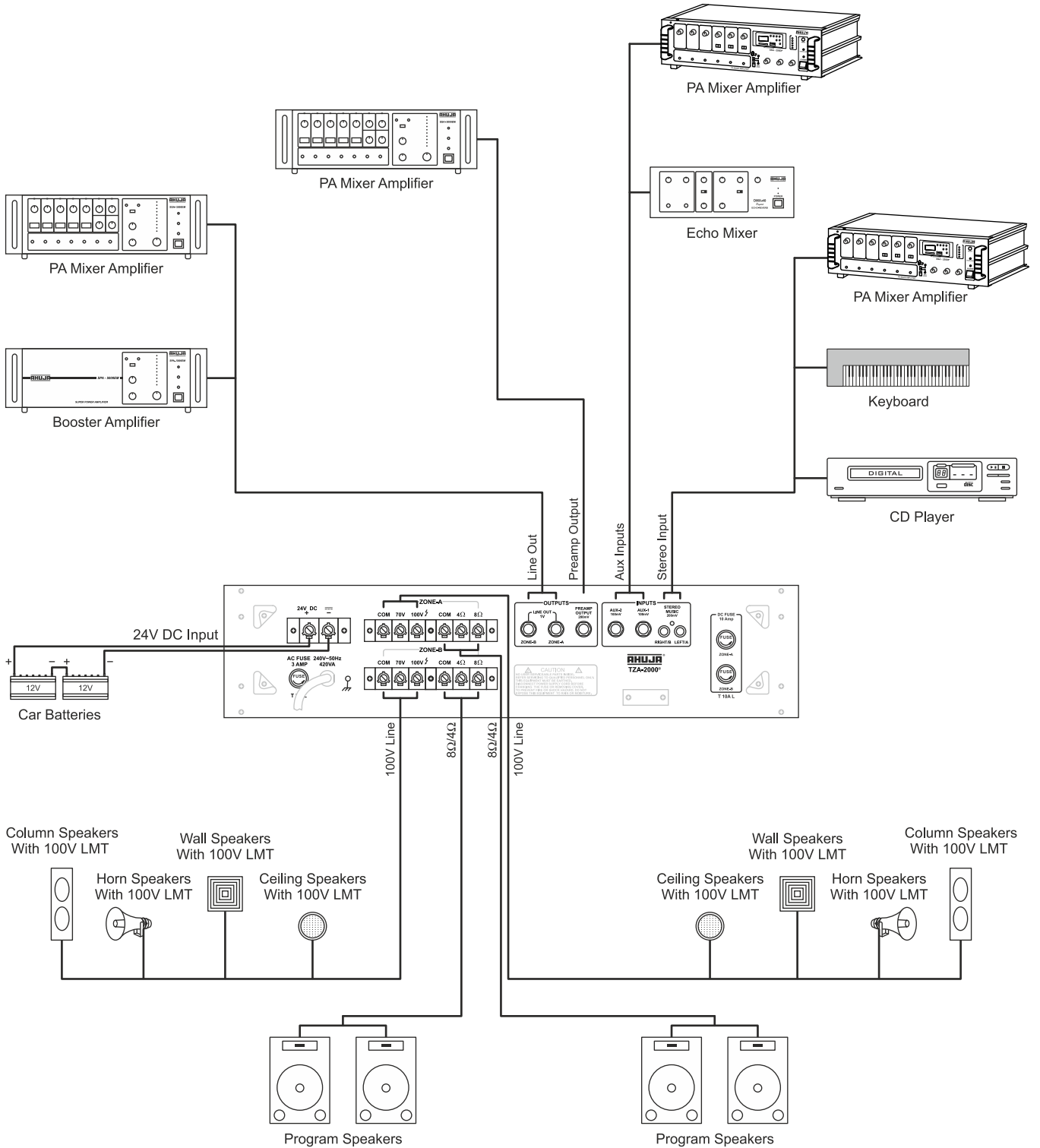

• Speaker Connection Guidelines

TZA-2000® is high-powered PA mixer amplifier. Therefore it is very important that correct loudspeaker connection are made to avoid damage to the amplifier or speakers.

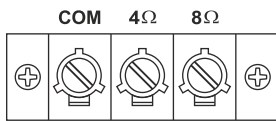

Low Impedance Speaker Connections

- Box type Speakers can be directly connected to Com-4Ω/8Ω Terminal Strip.
- No Driver Units / Horn Speakers / Column Speakers (with 100V LMT) should be connected to Com-4Ω/8Ω.

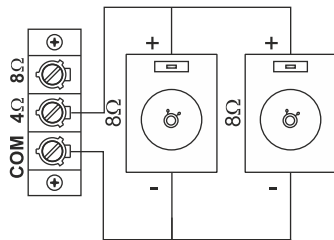

Resultant Impedance = $(8 \text{ Ohm} / 2) = 4 \text{ Ohm}$

Connecting two SRX-120DX Speakers on Each Zone

Two SRX-120DX Speakers (Each speaker can handle 100W of power) should be wired in a parallel combination to each zone as shown in figure. The resulting impedance will be 4Ω. The speaker system should be connected to the 4Ω tap of the amplifier.

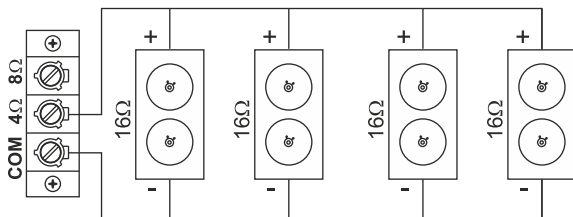

Resultant Impedance = $(16 \text{ Ohm} / 4) = 4 \text{ Ohm}$

Connecting Four SRX-50DX Speakers on Each Zone

Four SRX-50DX Speakers (Each speaker can handle 50W of power) should be wired in a parallel combination to each zone as shown in figure. The resulting impedance will be 4Ω. The speaker system should be connected to the 4Ω tap of the amplifier.

IMPORTANT

- When speakers are connected to COM-4Ω/8Ω Terminal Strip NO speakers should be connected to the Red Terminal Strip marked COM-70V/100V of the same zone.
- Speakers should be connected only to either COM-4Ω or COM-8Ω terminals as illustrated above but never to more than one set of terminals.

Speaker Connection Guidelines....

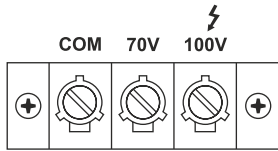

High Impedance Speakers or Speakers Using A 100V Line Matching Transformer

- Driver Units/Horn Speakers/Column Speakers with 100V Line Matching Transformers are only to be connected to Com-70V/100V Terminal Strip.
- When any of the above speakers are connected to the Com-70V/100V Terminal Strip of a zone than No Box Speakers should be connected to the COM-4Ω-8Ω Terminal Strip of that same zone.
- The power drawn from the amplifier should not exceed 200 Watts.

Connecting a combination of Driver Units and Columns Speakers with 100V LMTs on Zone A, Wall Speakers & Ceiling Speakers with 100V LMT on Zone B

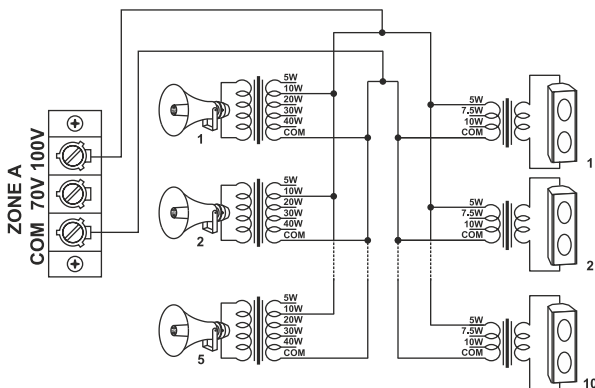

- 5 Driver Units with 100V LMTs connected at 10W and 10 Columns Speakers with 100V LMTs connected at 5W can be operated on Zone A.

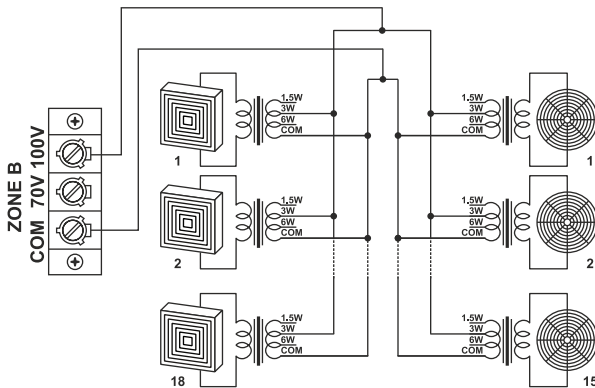

- 18 Wall Speakers with 100V LMT connected at 3W and 15 Ceiling Speakers with 100V LMT connected at 3W can be operated on Zone B.

Connecting a combination of Column Speakers and Wall Speakers with 100V LMTs on Zone A, Horn Speaker with 100V LMT on Zone B

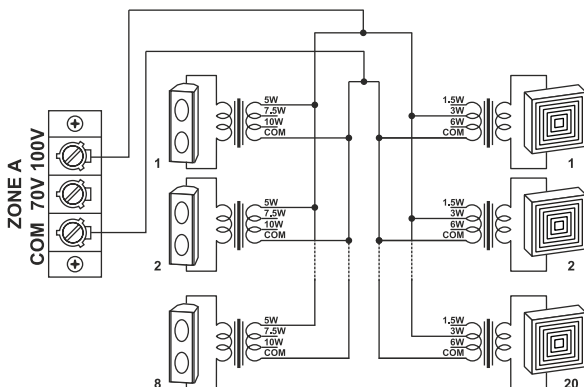

- 8 Column Speakers with 100V LMT connected at 5W tap and 20 Wall Speakers with 100V LMT connected at 3W can be operated on Zone A.

Speaker Connection Guidelines....

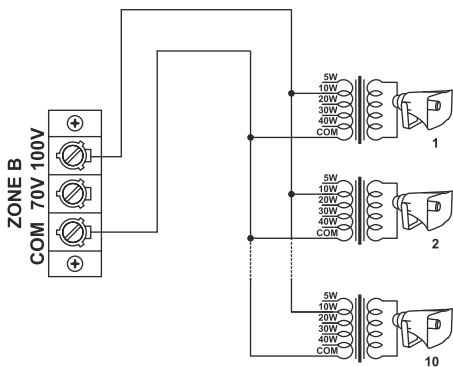

- On Zone B, 10 SUH-40XT Horn Speakers with 100V LMT connected at 10W can be operated.

Use of 70 Volt Line

A loudspeaker/Driver Unit with its LMT adjusted to the 15W tap, when connected to COM and 100V terminals on the amplifier's Terminal Strip will draw 15W from the amplifier but when the same is connected to COM and 70V it will only draw half power or 7.5W. A good use of 70V line tap can be made in installations where large number of speakers/driver units are to be installed for more even distribution of sound.

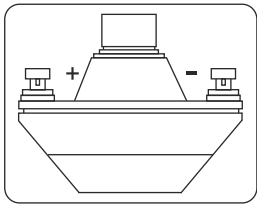

Correct Phasing of Loudspeakers

- When two or more Speakers/Units installed in the same area and are facing the same direction, it is essential that their cones/diaphragms act in unison. Otherwise the sound level of one speaker will be canceling the sound level of the other. To avoid any mistake, the terminals of Box speakers and the Driver Units are marked '+' & '-'. Always connect the COM of the Amplifier to '-' of speaker & 4/8 of the amplifier to the '+' of the speakers.
- In case of LMTs the COM of all the LMTs should be connected to the COM of the red strip terminal of the amplifier and the power tap to 100V line as shown in figure.

IMPORTANT

- When 70/100 Volt line is being used, no speakers/driver unit should be connected to 4 Ω /8 Ω (Low Impedance) Tap of the same zone.
- Loudspeaker/driver unit should be connected to either COM-100V or COM-70V terminals, but never to more than one set of terminals.

Typical Applications

Connecting One BR-250M On Each Zone To Make A 700W Stereo System

1. Connect the Output of the CD Player to the Stereo Input of TZA-2000® i.e., the Source Amplifier.
2. Connect the Line-Out of Zone A & Zone B from TZA-2000® to the Line-Inputs of BR-250M, using a patch-cord with 1/4" phone plugs at both ends.
3. In this manner the CD Player will feed both the amplifiers creating a 700W Stereo System.
4. Loudspeaker connections to both the amplifiers should be done independently.
5. The left and right speaker stacks comprise of two sets of two SAX-200DXs and two sets of two SRX-120DXs. Two SAX-200DXs should be connected in parallel to each BR-250M and Two SRX-120DXs should be connected in parallel to each zone of the TZA-2000.
6. Speaker system impedance should be matched to the output impedance of the amplifier and thus should be connected to the corresponding tap of the amplifier.
7. The Box Speaker / Driver Unit switch should be set to the Box Speaker side on both BR-250M amplifiers and the Mono / Stereo Selector Switch should be kept towards the Stereo position on each amplifier.
8. Finally when operating the system, the Bass and Treble controls of the TZA-2000 should be set to flat and any adjustments in the tonal quality of the sound if required should be adjusted only from the Source Amplifier i.e. the TZA-2000.

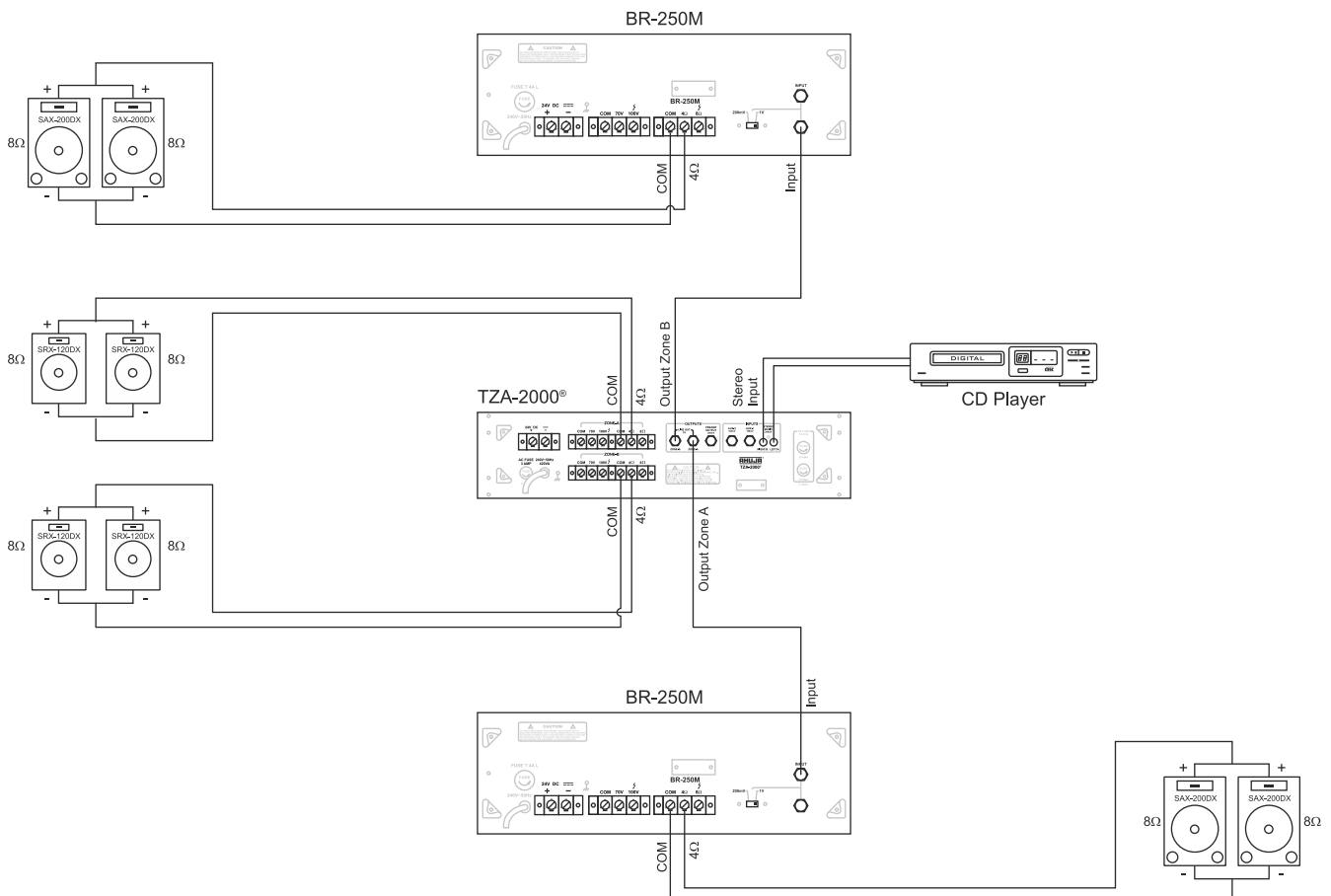

Connecting One TZA-4000EM To Make A 600W Stereo System

1. Connect the Output of the CD Player to the Stereo Input of TZA-2000® i.e., the Source Amplifier.
2. Connect the Line-Out of Zone A & Zone B from TZA-2000® to the Stereo Inputs Zone A (Left) & Zone B (Right) of TZA-4000EM respectively.
3. In this manner the CD Player will feed both the amplifiers creating a 600W Stereo System.
4. Loudspeaker connections to both the amplifiers should be done independently.
5. The left and right speaker stacks comprise of two sets of two SAX-200DXs and two sets of two SRX-120DXs. Two SAX-200DXs should be connected in parallel to each zone of the TZA-4000EM and Two SRX-120DXs should be connected in parallel to each zone of the TZA-2000.
6. Speaker system impedance should be matched to the output impedance of the amplifier and thus should be connected to the corresponding tap of the amplifier.
7. The Box Speaker / Driver Unit switch should be set to the Box Speaker side on TZA-4000EM amplifier and the Mono / Stereo Selector Switch should be kept towards the Stereo position.
8. Finally when operating the system, the Bass and Treble controls of the TZA-2000 should be set to flat and any adjustments in the tonal quality of the sound if required should be adjusted only from the Source Amplifier i.e. TZA-2000.

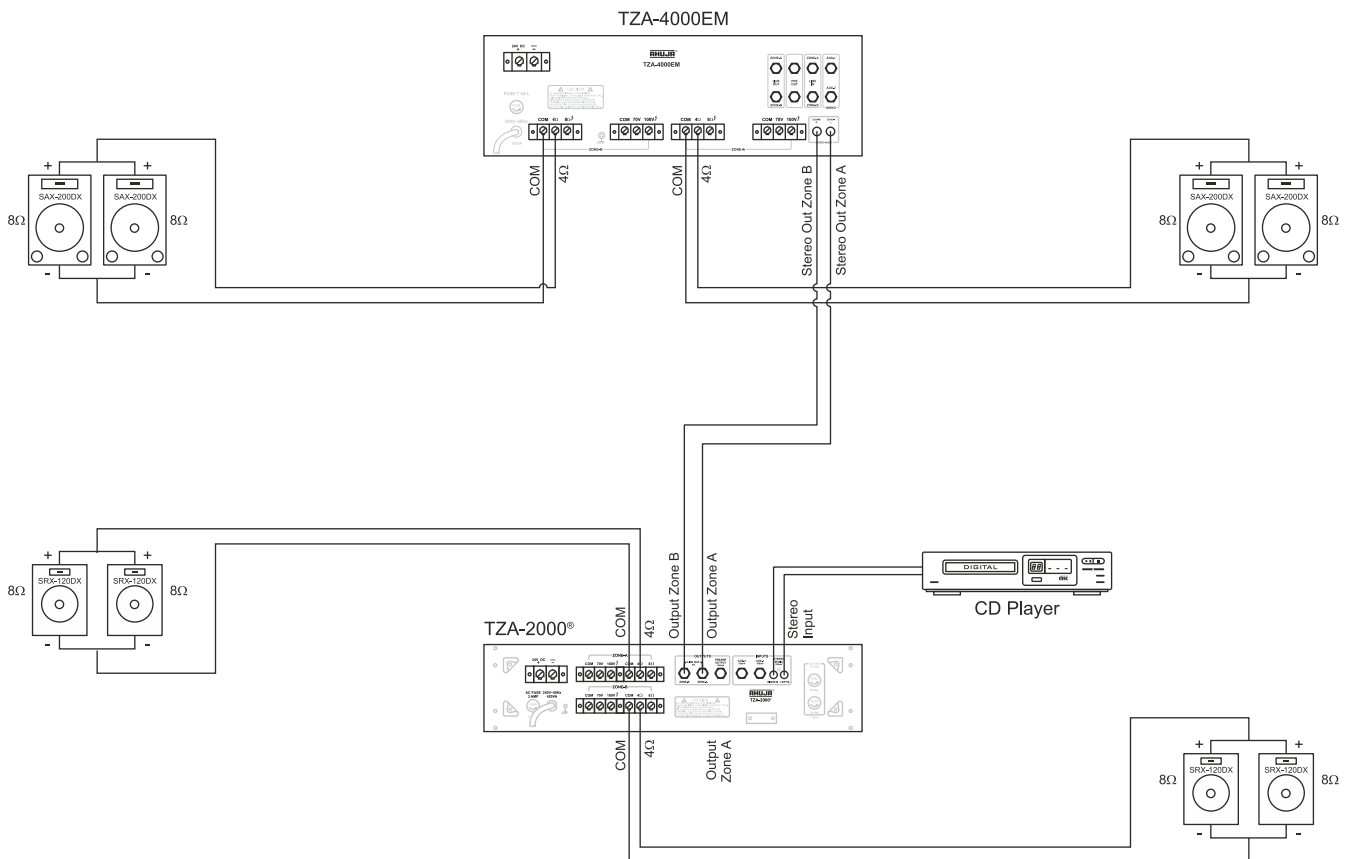

• Specifications

MODEL TZA-2000®	ZONE-A	ZONE-B
Power Output	130W RMS Max. 100W RMS at 10% THD 90W RMS at 5% THD 80W RMS at 2% THD	130W RMS Max 100W RMS at 10% THD 90W RMS at 5% THD 80W RMS at 2% THD
Output Regulation	≤2 dB no load to full load at 1kHz	
Input Channels	Mic: (1-6) 0.65mV / 4.7kΩ (Mic Source Imp. 50Ω to 1kΩ) Aux 1 & 2: 100mV / 470kΩ Stereo: Right Channel : 250mV / 47kΩ Left Channel : 250mV / 47kΩ	
Frequency Response	50Hz – 15,000Hz ± 3dB	50Hz – 15,000Hz ± 3dB
Signal to Noise Ratio	60dB	60dB
Tone Controls	Bass : ±10dB at 100Hz Treble : ±10dB at 10kHz	
Preamp Output	200mV / 600Ω	
Line Output	1V / 1kΩ	1V / 1kΩ
Output Taps for Speaker Matching	4 & 8Ω (for direct connections) 70 & 100V Line (for use with LMT)	
Power Supply	AC : 220-240V 50/60Hz DC : 24V (2×12V Car Battery)	
Protection	AC: Fuse 3Amp. (T 3A L) DC: Fuse 2×10Amp. (T 10A L) for both Zone	
AC Power Consumption	420 VA	
DC Power Consumption	3.25 A	3.25 A
Dimensions	W500 × H140 × D340 mm	
Weight	17.40 kg approx.	

- Design and Specifications are subject to change without notice owing to continuous product upgradation.
- Technical specifications are subject to production tolerances.

• For Your Records

- Model No.
- Serial No.
- Dealer's Name
- Dealer's Phone No. Fax No.
- Date of Purchase

Model and Serial Nos. are printed on the rear panel of the product.

AHUJA RADIOS

215, Okhla Industrial Estate, New Delhi-110020, INDIA
C-45, Phase-II, Noida-201305 (UP) INDIA
Tel.: +91-11-26831549, 41612474 Fax: +91-11-26847287
E-mail: ahuja@ahujaradios.com Website: www.ahujaradios.com

- Design and Specifications are subject to change without notice owing to continuous product up-gradation
- Technical specifications are subject to production tolerances.
- We cannot be held responsible for printing errors, should they occur.
- **AHUJA** is a registered trademark of Ahuja Radios in India and other countries.
- © Copyright Ahuja Radios, 2017. All rights reserved. Any unauthorized reproduction or use of logos, images or design elements is strictly prohibited by law.
- No part of this compilation may be reproduced in any manner or translated without written permission.

AHUJA®