

# AHUJA®

## PA Mixer Amplifier

400W RMS/600W Max.

OPERATION MANUAL

# TZA-4000® DPM

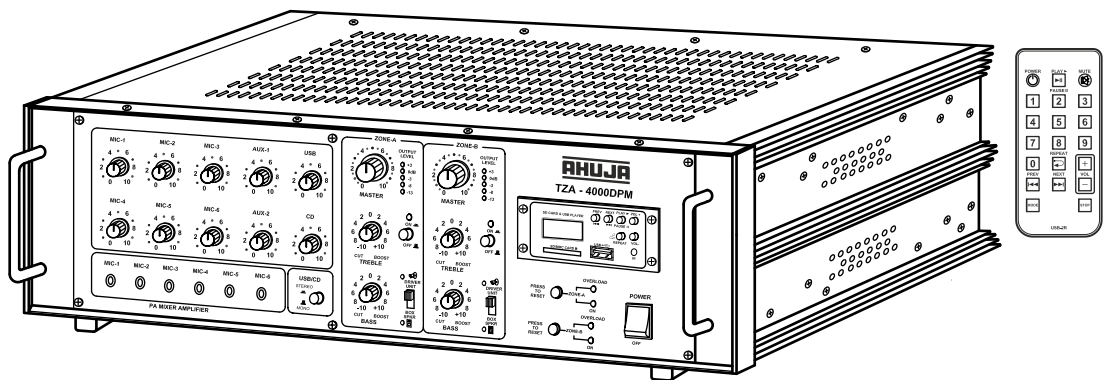

- ◆ Thank you for purchasing the AHUJA PA Mixer Amplifier.
- ◆ Please read this manual thoroughly before making connections and turning on the power. Following the instructions in this manual will enable you to obtain optimum performance from your new AHUJA PA Mixer Amplifier.
- ◆ Please retain this manual for future reference.

## • Safety Instructions

**Read the Instructions:** Please read all the instructions in this section carefully before installation or use of the product. All the safety instructions must be followed.

**Retain the Instructions:** Please retain this Instruction Manual for future reference.



This symbol, wherever it appears, alerts you to the presence of uninsulated hazardous voltage that may be sufficient to constitute a risk of electric shock. External wiring to any terminal marked with this symbol must be done by a trained and instructed person only.



This symbol, wherever it appears adjacent to a component, alerts you that the concerned component can only be replaced by another of the exact same specifications.

### WARNING

- To reduce the risk of electric shock, do not remove the top cover. No user serviceable parts inside. Refer all servicing to qualified personnel only.
- Before replacing any fuse, make sure the set is switched off and disconnected from the AC mains or any other power source. Replace a fuse only with another of exactly same specification.

### CAUTIONS

**Water & Moisture:** To reduce the risk of fire or electrical shock, do not expose this set to rain or moisture. Do not use this set near water or in a wet location. Do not keep any object filled with liquid, such as a vase, on top of this set. Do not insert or remove the AC mains plug with wet hands.

**Power Source:** The voltage & frequency of the AC mains supply, and the voltage of the external battery, (if applicable) to which this set can be connected, is marked on the rear panel of the set. Do not connect this set to any power source other than those specified on the rear panel.

**Power Cord Protection:** Do not cut, kink, damage or modify the AC power cord supplied with this set. Keep the AC power cord away from heaters and harmful chemicals. Do not keep any heavy object on the power cord.

**Operation on Generator:** When operating this set on a generator, make sure the set is switched off till the generator voltage has stabilized.

**Ventilation:** This set should be situated so that its location or position does not interfere with its proper ventilation. Do not cover the ventilation holes / slots. Do not insert or drop anything into the ventilation holes / slots.

**Stability:** This set must be kept in a stable and flat horizontal position, and never in a tilted position. Do not place this set on an unstable stand, tripod, bracket or mount. Do not use attachments which are not supplied or explicitly recommended by the manufacturer.

**Cover Strip:** The cover strip of the 100V / 70V audio output terminal strip, and of any other high voltage output terminal strip, must be replaced after making connections. Failure to do so may result in exposure to hazardous voltages.

**Earthing:** This set must be earthed properly before use. A wire from the Earth terminal on the rear panel must be connected to electrical earth.

**Cleaning:** Disconnect this equipment from the AC mains and external battery before cleaning. Clean with a damp cloth, but do not allow any liquid to enter the set. Do not clean with liquids or aerosols.

**Exposure to Heat:** Do not touch the heatsinks while the set is working.

## • Table of Contents

<b>Contents</b>	<b>Page No.</b>
• <b>Features/General Description of Product</b> .....	<b>4</b>
• <b>Front Panel Controls &amp; Features</b> .....	<b>5</b>
• <b>Rear Panel Controls &amp; Features</b> .....	<b>6</b>
• <b>MP3 Playback Facility: Controls &amp; Features</b> .....	<b>7</b>
• <b>Interconnections</b> .....	<b>8</b>
• <b>Speaker Connection Guidelines</b> .....	<b>9</b>
• <b>Guideline to Use Different Input Sources</b> .....	<b>12</b>
• <b>Typical Applications</b> .....	<b>13</b>
• <b>Specifications</b> .....	<b>16</b>

## • Features/General Description of Product

- Ideal for use in a wide variety of 2- Zone PA applications where high power is required.
- TZA-4000®DPM is a 400 Watts 2 zone amplifier offering 6 independent unbalanced Mic Inputs & 2 Aux inputs to feed one or both zone. Each zone has its independent tone and master controls for separate and combined operation.
- Built-in MP3 Playback Facility with USB, SD and MMC Card Reader.
- Remote Control is provided for ease of operation of MP3 Player.
- Built-in LCD Display with MP3 Player (displays the track number played).
- Independant level control for each input.
- Stereo Music Input through separate left & right channels is provided to connect MP3 Player or CD Player.
- Line Inputs have been provided for each zone separately for connecting External Mixer. Line Outputs provided for each zone separately for connecting booster amplifier for more power.
- Pre-Amp Output provided for each zone for connecting another amplifier, or a Recorder for recording the programme.
- The amplifier also has Mono/Stereo input switch. This can be used for selecting mono or stereo operation of MP3 Player, or feeding input through the CD/Stereo music input.
- TZA-4000®DPM has individual Zone ON / OFF facility. Sound from each zone can be switched on and off without disturbing the settings of tone and volume controls.
- Box Speaker / Driver Unit selector switch has been provided for protecting the Driver Unit's diaphragm from unwanted low frequencies. Box speakers can reproduce the full spectrum of audio frequencies but driver units cannot reproduce very low frequencies. Hence the switch should be positioned to the driver unit side when Driver Units, Horns and column speakers are connected.
- Circuit protector device has been provided for each zone. It safeguards the amplifier against overload and short circuit.
- Power losses in speaker wirings are reduced as the Two zones share the delivering of 400W of power.
- Provision for automatic changeover from AC to battery operation ensures continuity of program.
- Protection provided against reverse polarity of battery connection.
- Ease of operation, combined with service accessibility has been optimized in the design.

## • Front Panel Controls & Features

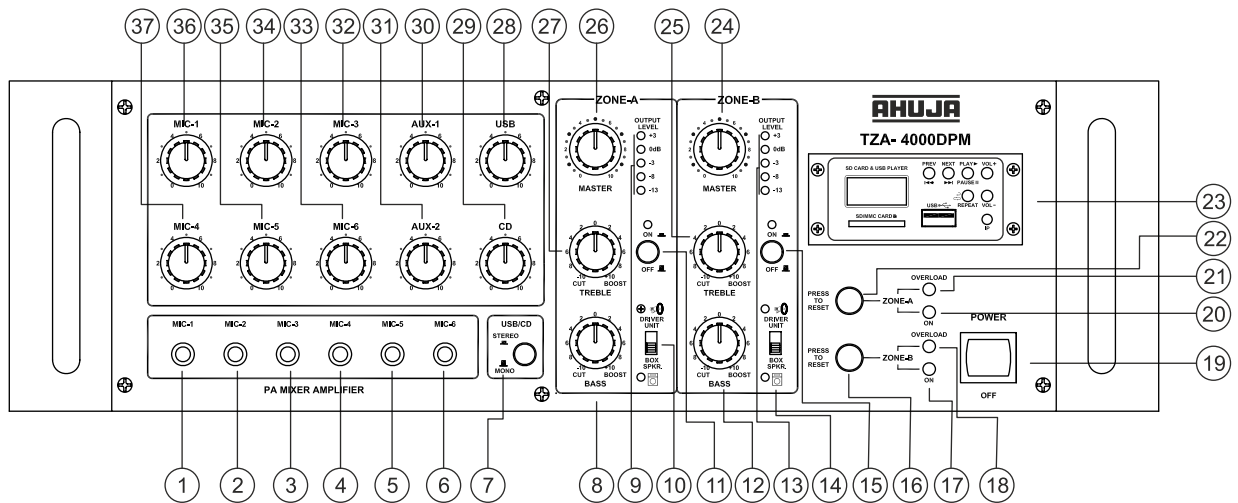

1. **MIC-1 Input Jack Socket**  
For accepting unbalanced signal from a low impedance microphone.
2. **MIC-2 Input Jack Socket**
3. **MIC-3 Input Jack Socket**
4. **MIC-4 Input Jack Socket**
5. **MIC-5 Input Jack Socket**
6. **MIC-6 Input Jack Socket**
7. **Mono/Stereo Switch**  
For selecting the music programme in mono or stereo modes.
8. **BASS Control (Zone A)**  
For cutting or boosting the signal level of low frequencies.
9. **LED Array (Zone A)**  
These indicate the output level of the amplifier for Zone A.
10. **BOX SPEAKER / DRIVER UNIT Selector Switch (Zone A)**
11. **Zone-A ON / OFF SWITCH with indicator LED**
12. **BASS Control (Zone B)**
13. **LED Array (Zone B)**
14. **BOX SPEAKER / DRIVER UNIT Selector Switch (Zone B)**
15. **Zone-B ON / OFF SWITCH with indicator LED**
16. **RESET button (Zone B)**  
This button pops out when the circuit protector trips. The circuit protector protects the amplifier from getting damaged on account of wrong and mismatched loudspeaker connections, short circuits and when the speakers are drawing more than 500W per channel power. Rectify the cause and press the RESET button for resetting normal operation of the amplifier.
17. **POWER LED (Zone B)**  
This LED glows when the zone B of the amplifier is switched ON.
18. **OVERLOAD LED (Zone B)**  
This LED glows when the circuit protector trips.
19. **POWER Switch**  
Push the top part of the knob to switch the amplifier ON. Push the bottom part of the knob to switch the amplifier OFF.
20. **POWER LED (Zone A)**
21. **OVERLOAD LED (Zone A)**
22. **RESET button (Zone A)**
23. **MP3 PLAYBACK FACILITY**  
(For Description see page no.7)
24. **MASTER Volume Control (Zone B)**  
For adjustment of the overall volume level from Zone B.
25. **TREBLE Control (Zone B)**
26. **MASTER Volume Control (Zone A)**
27. **TREBLE Control (Zone A)**
28. **USB Volume Control**
29. **CD Volume Control**
30. **AUX-1 Volume Control**
31. **AUX-2 Volume Control**
32. **MIC-3 Volume Control**
33. **MIC-6 Volume Control**
34. **MIC-2 Volume Control**
35. **MIC-5 Volume Control**
36. **MIC-1 Volume Control**
37. **MIC-4 Volume Control**

## • Rear Panel Controls & Features

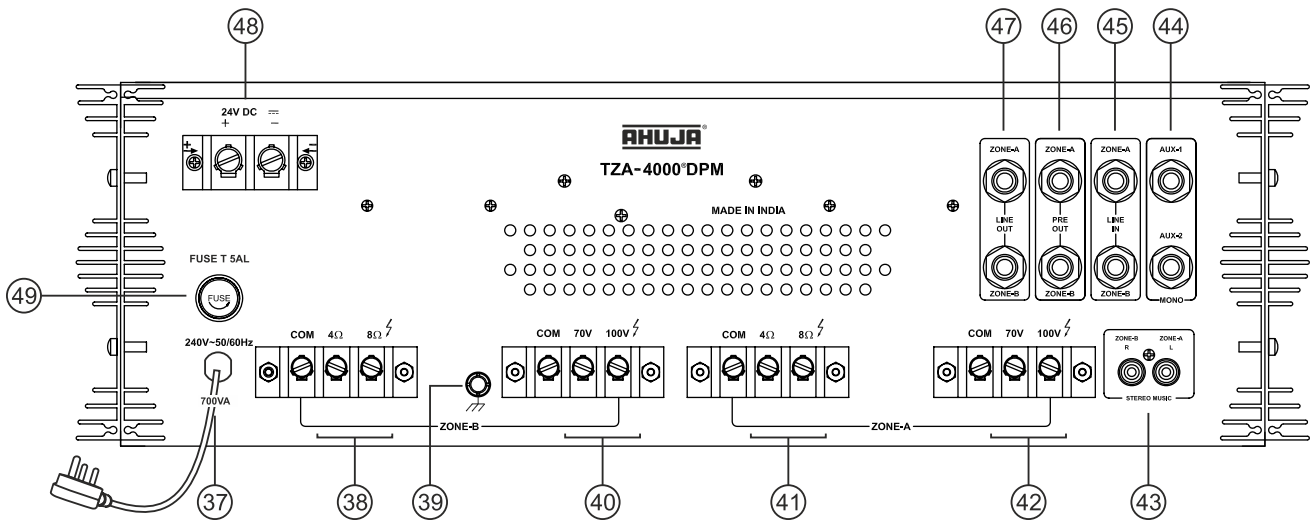

**37. 3 CORE AC MAINS CABLE With Plug**

**38. SPEAKER Terminal Block for Zone B (4Ω and 8Ω)**

For connecting low impedance speakers.

**39. EARTH Terminal**

**40. SPEAKER Terminal Block for Zone B (70V, 100V)**

For connecting speakers with 100V line matching transformers.

**41. SPEAKER Terminal Block for Zone A (4Ω and 8Ω)**

**42. SPEAKER Terminal Block for Zone A (70V, 100V)**

**43. STEREO RCA Socket**

These two RCA Jacks marked 'L' & 'R' are for connecting STEREO Input from MP3 Player or CD Player.

**44. AUX-1 & AUX-2 Input Jack Sockets**

For accepting an unbalanced signal from an auxiliary source like a Tuner, MP3 Player, Echo or unit Mixer etc.

**45. LINE INPUT JACK SOCKET (Zone A & Zone B)**

For connecting inputs such as a CD Player. Also for connecting external Mixer to enhance the number of inputs.

**46. PREAMPLIFIER Output Jack Sockets (Zone A & Zone B)**

For connecting to the Aux input of another amplifier or a Recorder for recording purpose.

**47. LINE OUTPUT JACK SOCKET (Zone A & Zone B)**

For connecting to a booster amplifier to obtain combined higher power output.

**48. BATTERY Terminal Block**

For connecting two 12V Car Batteries in series (which becomes 24V) as standby power source.

**49. AC MAINS FUSE Rating 5AMP. 250V (T 5A L)**

This protects the amplifier from any excessive current flow. Replace only with a 5 ampere 250V time delay fuse.

### Caution

- **To avoid electric shock:** The equipment must be earthed properly before operating it to avoid electric shock. A wire from the Earth Terminal must be connected to electrical earth for safe operation.
- **Replacement of battery for remote control:** There can be danger of explosion if battery is incorrectly replaced. Replace only with CR2025 lithium button cell.

# • MP3 Playback Facility: Controls & Features

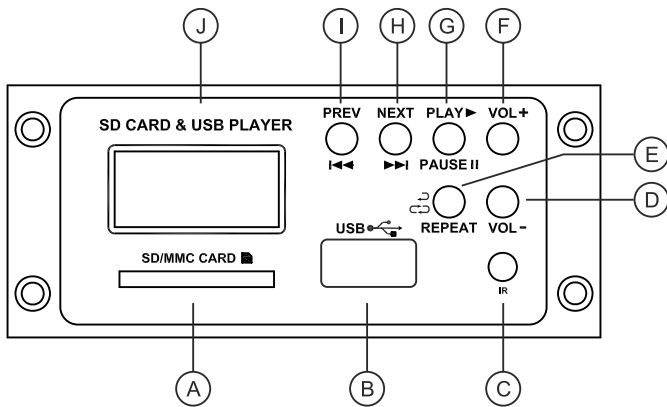

## Remote Control

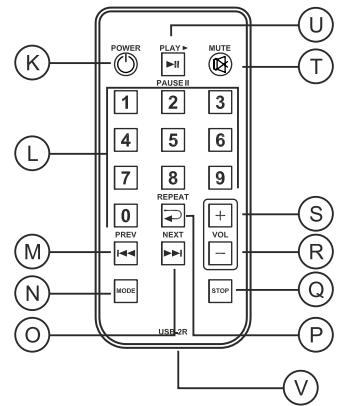

- A. SD/MMC Card Connector:** Insert the SD/MMC Card into its appropriate slot to play. When taking out the card, pull the card to take out.

While inserting SD/MMC card into the slot, ensure that the card is inserted in such a way that all pins are facing downward and cut is towards right as shown in figure.

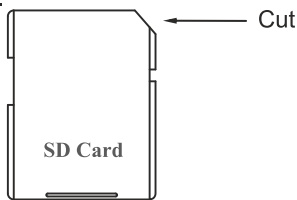

- B. USB Connector:** Insert the USB drive here. While inserting USB drive into the USB connector, hold the USB drive in such a way that hollow part of the USB drive is upwards as shown in Figure.

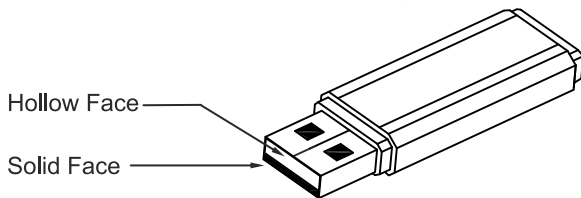

Any forceful insertion in wrong direction will damage the connector.

- C. IR Sensor:** Picks up signal from the Remote control. Point the Remote control toward this sensor when using the remote control.
- D. VOL-:** To decrease volume level of MP3 player.
- E. REPEAT ↻:** Press once to repeat the song being played. Press again to repeat all the songs.
- F. VOL+:** To increase volume level of Mp3 player.
- G. PLAY/PAUSE:** Press PLAY/PAUSE once to Pause if music is already playing. Press PLAY/PAUSE again to resume playing. Play will resume from the same point where it had stopped.

- H. NEXT:** Press NEXT to select next forward music track. Pressing NEXT repeatedly will move the system to successively next forward tracks.
- I. PREV:** Press PREV to Select the previous track. Pressing PREV repeatedly will move the system to successively previous tracks.
- J. LCD Display:** Displays 3 digits of the track selected to play i.e 001 to 999. During play, displays the time duration of the track played.

## Remote Control

- K. Power:** Press once to switch off MP3 digital player, press again to switch ON.
- L. Number key 0 to 9.** To choose the track number to be played.
- M. PREV:** To select the previous track.
- N. MODE:** To select SD or USB if both are inserted.
- O. NEXT:** Press to select the next track.
- P. REPEAT:** Press once to repeat the song being played. Press again to repeat all the songs.
- Q. STOP:** Press to stop the track being played.
- R. Vol-:** Press to decrease the volume of Digital Player.
- S. Vol+:** Press to increase the volume of Digital Player.
- T. MUTE:** Press once to mute the sound, press again to resume the sound.
- U. PLAY/PAUSE:** Press Play/Pause once to Pause when music is already playing. Press Play/Pause again to resume playing.
- V. Battery Replacement:** Pull out the battery tray and replace the battery with positive electrode facing upwards as shown in fig. below. Push the battery compartment back to the close position. Use CR2025 or equivalent lithium coin cell.

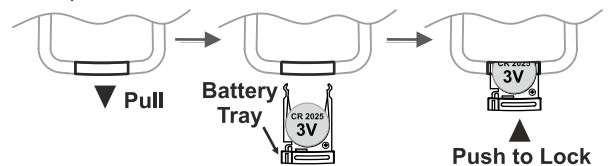

• **Interconnections**

**REAR PANEL - TZA-4000®DPM**

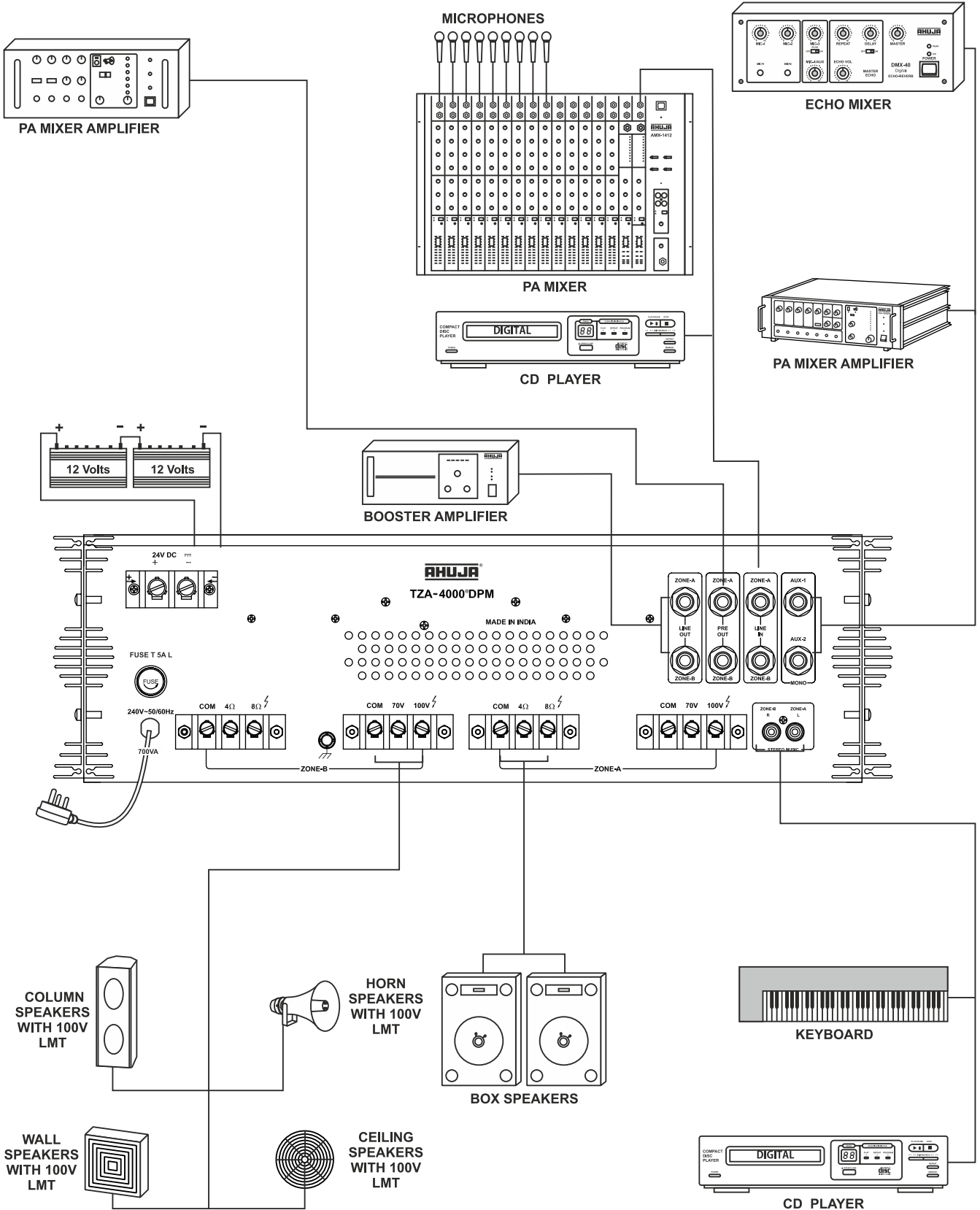



## • Speaker Connection Guidelines

**TZA-4000®DPM is a high-powered PA mixer amplifier. Therefore it is very important that correct loudspeaker connections are made to avoid damage to the amplifier or speakers.**

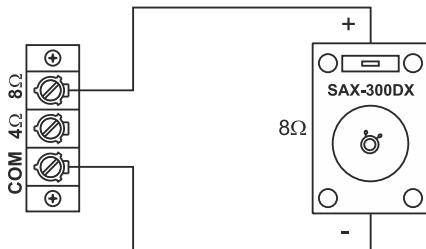
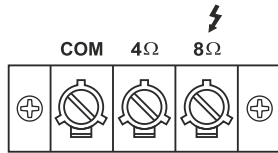

*Resultant Impedance = 8 ohm*

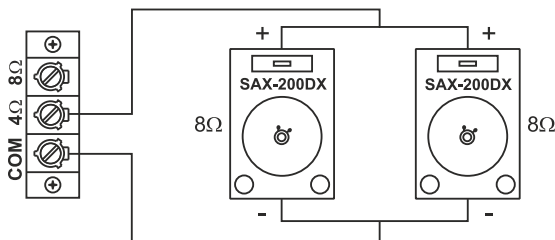

*Resultant Impedance = 8 ohm/2 = 4 ohm*

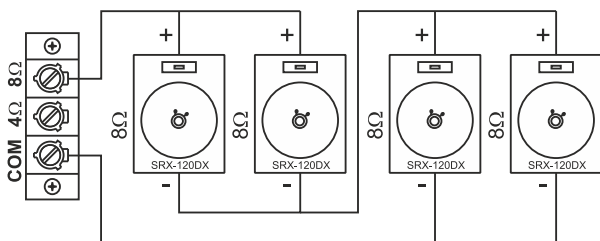

*Resultant Impedance = (8 ohm/2) x2 = 8 ohm*

### Low Impedance Speaker Connections

- Box type Speakers can be directly connected to COM - 4Ω / 8Ω Terminal Strip.
- The Box Speaker / Driver Unit switch must be kept at Box Speaker position. If by mistake the switch remains in Driver Unit position the quality of sound will not be rich and natural.
- No Driver Units / Horn Speakers / Column Speakers (with 100V LMT) should be connected to COM - 4Ω / 8Ω.

### Connecting One SAX-300DX Speaker on Each Zone

One SAX-300DX speaker (Each speaker can handle 300W of power) should be connected to 8Ω taps on each zone as shown in figure.

### Connecting Two SAX-200DX Speakers on Each Zone

Two SAX-200DX Speakers (Each speaker can handle 200W of power) should be wired in a parallel to each zone as shown in figure. The resulting impedance will be 4Ω. The speaker system should be connected to the 4Ω tap of each zone of the amplifier.

### Connecting Four SRX-120DX Speakers on Each Zone

Four SRX-120DX Speakers (Each speaker can handle 100W of power) should be wired in a parallel-series combination to each zone as shown in figure. Two groups of two speakers each are connected in parallel and then the groups are connected in series. The resulting impedance will be 8Ω. The speaker system should be connected to the 8Ω tap of each zone of the amplifier.

### IMPORTANT

- When speakers are connected to COM - 4Ω / 8Ω Terminal Strip NO speakers should be connected to the Red Terminal Strip marked COM - 70V / 100V of the same zone.
- Speakers should be connected only to either COM - 4Ω or COM - 8Ω terminals of the same zone as illustrated above but never to more than one set of terminals.

# Speaker Connection Guidelines....

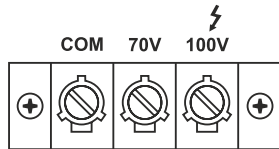

## High Impedance Speakers or Speakers Using A 100V Line Matching Transformer

- Driver Units / Horn Speakers / Column Speakers with 100V Line Matching Transformers are only to be connected to COM - 70V / 100V Terminal Strip.
- When any of the above speakers are connected to the COM - 70V / 100V Terminal Strip of a zone then No Box Speakers should be connected to the COM - 4Ω - 8Ω Terminal Strip of that same zone.
- The power drawn from each zone of the amplifier should not exceed 200 Watts.

## Connecting a combination of Driver Units and Columns Speakers with 100V LMTs on Zone A, Wall Speakers & Ceiling Speakers with 100V LMT on Zone B

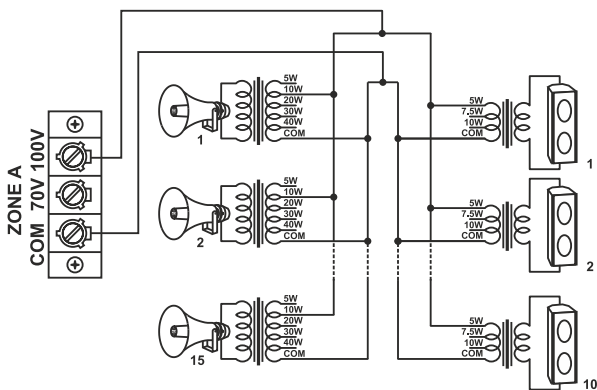

- 15 Driver Units with 100V LMTs connected at 10W and 10 Columns Speakers with 100V LMTs connected at 5W can be operated on Zone A.

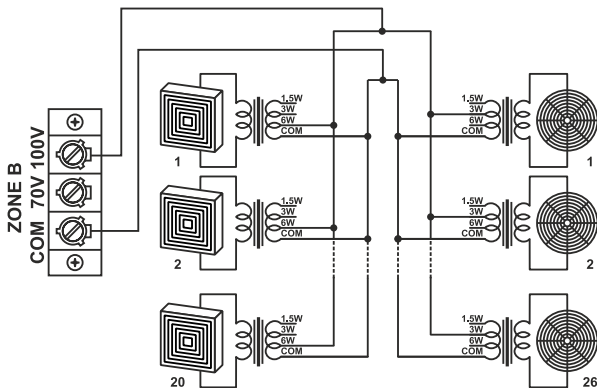

- 20 Wall Speakers with 100V LMT connected at 6W and 26 Ceiling Speakers with 100V LMT connected at 3W can be operated on Zone B.

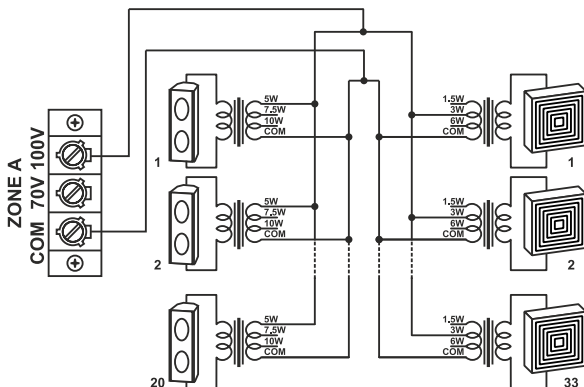

## Connecting a combination of Column Speakers and Wall Speakers with 100V LMTs on Zone A, Horn Speaker with 100V LMT on Zone B

- 20 Column Speakers with 100V LMT connected at 5W tap and 33 Wall Speakers with 100V LMT connected at 3W can be operated on Zone A.

## Speaker Connection Guidelines....

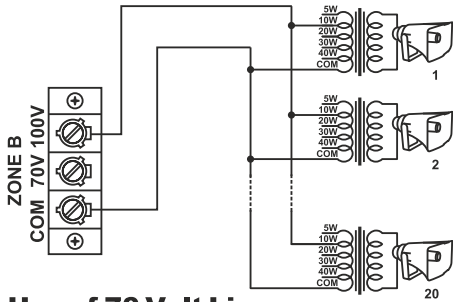

### Use of 70 Volt Line

A loudspeaker / Driver Unit with its LMT adjusted to the 15W tap, when connected to COM and 100V terminals on the amplifier's Terminal Strip will draw 15W from the amplifier but when the same is connected to COM and 70V it will only draw half power i.e. 7.5W. A good use of 70V line tap can be made in installations where large number of speakers/ driver units are to be installed for more even distribution of sound.

- On Zone B, 20 SUH-40XT Horn Speakers with 100V LMT connected at 10W can be operated.

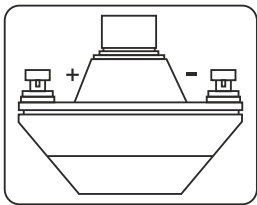

### Correct Phasing of Loudspeakers

- When two or more Speakers / Units installed in the same area and are facing the same direction, it is essential that their cones/diaphragms act in unison. Otherwise the sound level of one speaker will be canceling the sound level of the other. To avoid any mistake, the terminals of Box speakers and the Driver Units are marked '+' & '-'. Always connect the COM of the Amplifier to '-' of speaker & 4 / 8Ω of the amplifier to the '+' of the speakers.
- In case of LMTs the COM of all the LMTs should be connected to the COM of the red strip terminal of the amplifier and the power tap to 100V line as shown in figure.

## • **Guideline to Use Different Input Sources**

### **TO PLAY USB / SD CARD / MMC CARD FROM THE INBUILT MP3 DIGITAL PLAYER**

- Insert either the USB or SD/MMC card into the inbuilt MP3 Player, select the desired track number, and press PLAY.
- Keep Stereo / Mono switch on the front panel (shown as item 7 on page 5) in mono position if speakers on Zone-A are all at a different location from the speakers connected to Zone-B (e.g box speakers are connected to Zone-A and placed inside a hall while horn speakers are connected to Zone-B and placed outside). Keep this switch on Stereo position if all speakers are in the same area. Some on the left & some on the right.
- Level of music can be controlled by the USB control.
- Overall level can be set from the Master controls.

### **TO PLAY A STEREO CD PLAYER THROUGH RCA JACKS**

- Connect the CD Player to the RCA jacks marked STEREO MUSIC on the rear panel (shown as item 43 on page 6)
- Keep Stereo / Mono switch on the front panel (shown as item 7 on page 5) in mono position if speakers on Zone-A are all at a different location from the speakers connected to Zone-B (e.g box speakers are connected to Zone-A and placed inside a hall while horn speakers are connected to Zone-B and placed outside). Keep this switch on Stereo position if all speakers are in the same area. Some on the left & some on the right.
- Level of music can be controlled by the CD control.
- Overall level can be set from the master control.

### **TO USE MICROPHONES ALONG WITH A CD PLAYER/USB PLAYER OR MIXER**

- Connect the microphones to the appropriate Mic socket on the front panel. Set mic level from the appropriate Mic control.
- Connect the CD Player or Mixer to RCA jack on the rear panel (shown as item 43 on page 6) or insert USB.
- Level of the CD Player or Mixer can be set from the appropriate CD control or USB control if USB input is used.
- Keep Stereo/Mono switch on the front panel ((shown as item 7 on page 5) as desired. Selection of Stereo/Mono switch will be effective only for music programs selected through either CD or USB. Programs through Mic or Aux are always mono.
- Overall level can be set from master control.

## • Typical Applications

### Connecting BR-250M On Each Zone To Make A 900W Stereo System

1. Connect the Output of the CD Player to the Stereo Music Input of TZA-4000®DPM i.e. the SOURCE AMPLIFIER
2. Connect the Line-Out of Zone A & Zone B from TZA-4000®DPM to the Line-Inputs of 2 nos. BR-250M, using a patch-cord with ¼" phone plugs at both ends.
3. In this manner the CD Player will feed all the three amplifiers creating a 900W Stereo System.
4. Loudspeaker connections to each amplifier should be done independently.
5. The left and right speaker stacks comprise of four sets of two SAX-200DXs. Two SAX-200DXs should be connected in parallel to each BR-250M and Two SAX-200DXs should be connected in parallel to each zone of the TZA-4000®DPM.
6. Speaker system impedance should be matched to the output impedance of the amplifier and thus should be connected to the corresponding tap of the amplifier.
7. The Box Speaker/Driver Unit switch should be set to the Box Speaker side on all the amplifiers and the Mono/Stereo Selector Switch should be kept at the Stereo position on TZA-4000®DPM.
8. Finally when operating the system, the Bass and Treble controls of the BR-250M should be set to flat and any adjustments in the tonal quality of the sound if required should be adjusted only from the SOURCE AMPLIFIER i.e. the TZA-4000®DPM.

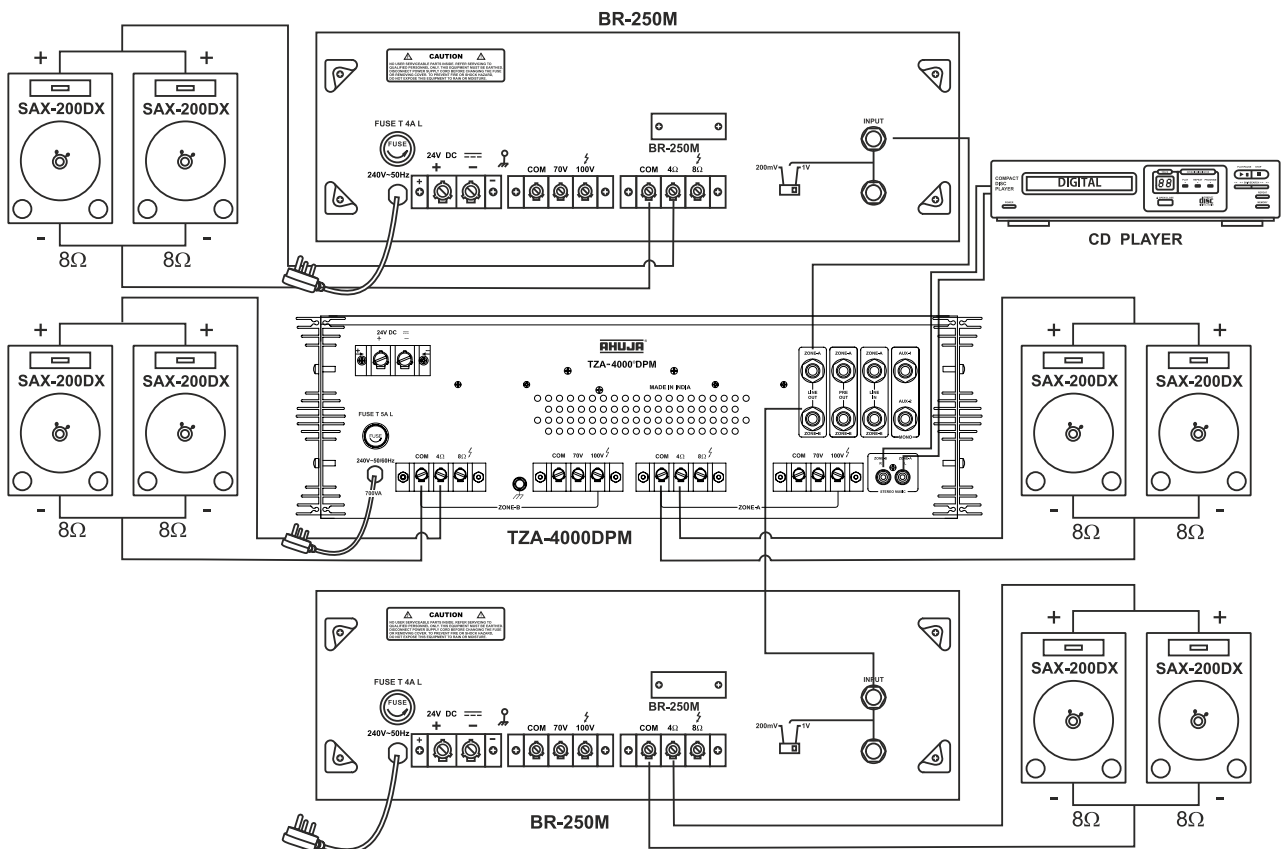

## Typical Applications....

### Connecting SPA-5000EM On Each Zone To Make A 1400W Stereo System

1. Connect the Output of the CD Player to the Stereo Music Input of TZA-4000®DPM i.e. the SOURCEAMPLIFIER.
2. Connect the Line-Out of Zone A & Zone B from TZA-4000®DPM to the Line-Inputs of SPA-5000EM using a patch-cord with ¼" phone plugs at both ends.
3. In this manner the CD Player will feed all the three amplifiers creating a 1400W Stereo System.
4. Loudspeaker connections to the amplifiers should be done independently.
5. The left and right speaker stacks comprise of two sets of two SAX-300DXs and two sets of two SAX-200DXs. Two SAX-300DXs should be connected in parallel to each SPA-5000EM and Two SAX-200DXs should be connected in parallel to each zone of the TZA-4000®DPM.
6. Speaker system impedance should be matched to the output impedance of the amplifier and thus should be connected to the corresponding tap of the amplifier.
7. The Box Speaker/Driver Unit switch should be set to the Box Speaker side on all the amplifiers and the Mono/Stereo Selector Switch should be kept at the Stereo position on TZA-4000®DPM.
8. Finally when operating the system, the Bass and Treble controls of the SPA-5000EM should be set to flat and any adjustments in the tonal quality of the sound if required should be adjusted only from the SOURCE AMPLIFIER i.e. the TZA-4000®DPM.

*(Refer to page 15 for illustration)*

## Connecting SPA-5000EM On Each Zone To Make A 1400W Stereo System

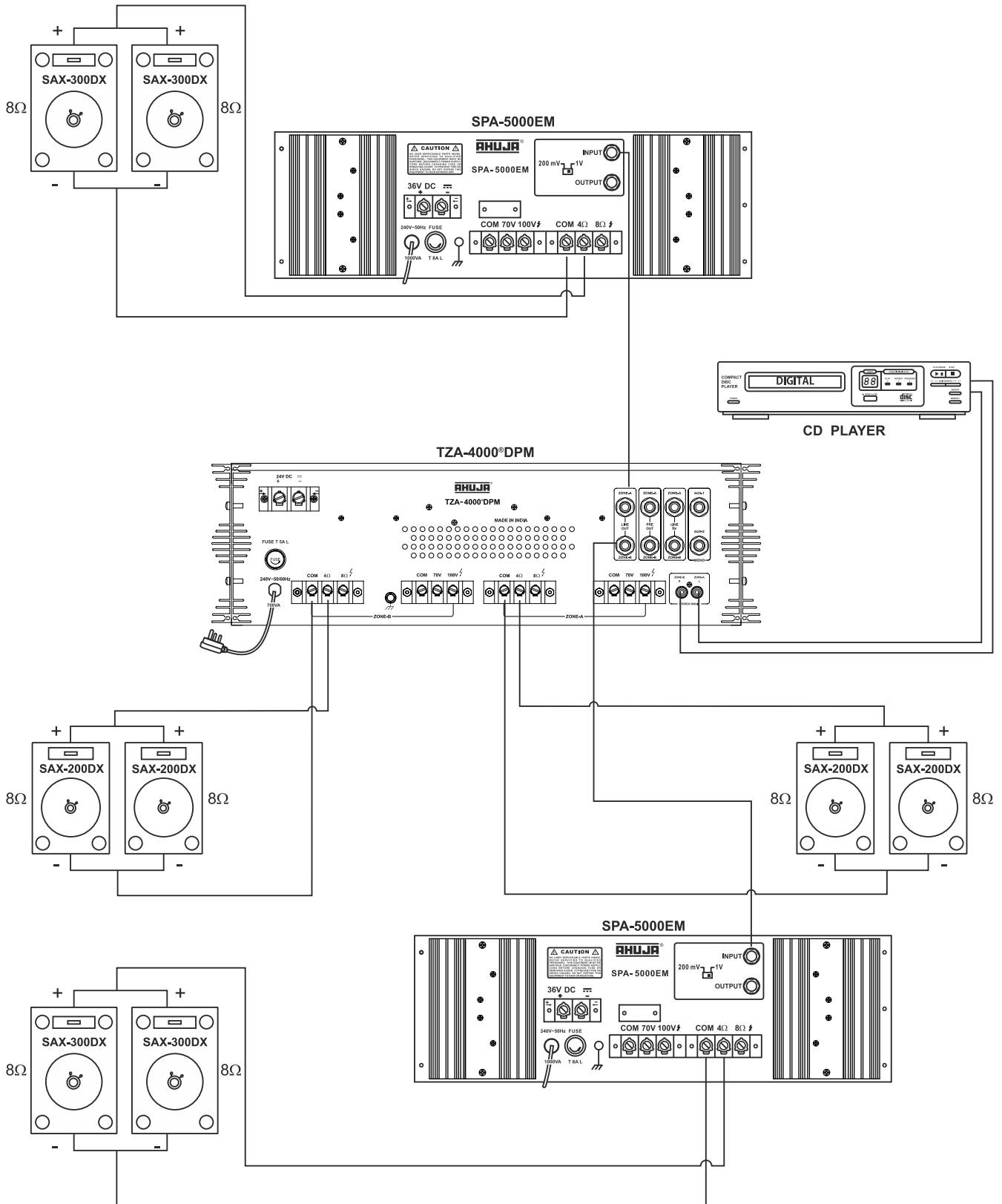

## • Specifications

MODEL TZA-4000®DPM	ZONE-A	ZONE-B
<b>Power Output</b>	300W RMS Max. 200W RMS at 10% THD 180W RMS at 5% THD 165W RMS at 2% THD	300W RMS Max. 200W RMS at 10% THD 180W RMS at 5% THD 165W RMS at 2% THD
<b>Output Regulation</b>	≤ 2 dB no load to full load at 1kHz	
<b>Input Channels</b>	<b>Mic (1-6):</b> 0.6mV / 4.7kΩ (Mic Source Imp. 50Ω to 1kΩ) <b>Aux 1 &amp; 2:</b> 100mV / 470kΩ <b>Stereo music Input:</b> Left Channel : 200mV / 100kΩ Right Channel : 200mV / 100kΩ <b>Line Input:</b> Left Channel : 1V / 50kΩ Right Channel : 1V / 50kΩ	
<b>MP3 Playback</b>	Built-in MP3 Playback facility (USB, SD & MMC Card) Remote Control provided	
<b>Frequency Response</b>	50Hz – 15,000 Hz ±3dB	50Hz – 15,000 Hz ±3dB
<b>Signal to Noise Ratio</b>	60dB	60dB
<b>Tone Controls:</b> <b>Switch at Box Speaker Position</b> <b>Switch at Driver Unit Position</b>	Bass: ±10dB at 100Hz Treble: ±10dB at 10kHz Bass: -10dB at 100Hz Treble: ±10dB at 10kHz	Bass: ±10dB at 100Hz Treble: ±10dB at 10kHz Bass: -10dB at 100Hz Treble: ±10dB at 10kHz
<b>Preamp Output</b>	200mV / 600Ω	200mV / 600Ω
<b>Line Output</b>	1V / 1kΩ	1V / 1kΩ
<b>Output Taps for Speaker Matching</b>	4 & 8Ω (for direct connections) 70 & 100V Line (for use with LMT)	4 & 8Ω (for direct connections) 70 & 100V Line (for use with LMT)
<b>Power Supply</b>	AC : 220-240V 50 / 60 Hz; DC : 24V (2×12V Car Battery)	
<b>Protection</b>	AC: Fuse 5Amp. 250V (T 5A L); DC: 12Amp. Circuit Protector for each Zone	
<b>AC Power Consumption</b>	700 VA	
<b>DC Power Consumption</b>	4.5 A	4.5 A
<b>Dimensions</b>	W510 × H172 × D385 mm	
<b>Weight</b>	24.20 kg approx.	

### AHUJA RADIOS

215, Okhla Industrial Estate, New Delhi-110020, INDIA

C-45, Phase-II, Noida-201305 (UP) INDIA

Tel.: +91-11-26831549, 41612474 Fax: +91-11-26847287

E-mail: ahuja@ahujaradios.com Website: www.ahujaradios.com

- Design and Specifications are subject to change without notice owing to continuous product up-gradation
- Technical specifications are subject to production tolerances.
- We cannot be held responsible for printing errors, should they occur.
- AHUJA is a registered trademark of Ahuja Radios in India and other countries.
- © Copyright Ahuja Radios, 2014. All rights reserved. Any unauthorized reproduction or use of logos, images or design elements is strictly prohibited by law.
- No part of this compilation may be reproduced in any manner or translated without written permission.

